



Installation Instructions & User Guide



A&A Manufacturing

Rev. 20191126
© Copyright 2019 A&A Manufacturing. All rights reserved.



Prior to Installation



WARNING

The QuikSkim must be installed by a licensed or certified plumber or a qualified pool professional adhering to all applicable local codes and ordinances.

IMPORTANT

The installer must read this manual completely before attempting installation. Consult A&A Manufacturing with any question regarding this product. This guide must be left with the pool owner or operator.

When a DE filter is used on the system, the return line feeding the venturi nozzle must be closed to prevent the filter media from discharging into the water body.

NOTE:

The venturi port is a return line not a suction or equalizer line. Blocking the discharge flow from the venturi nozzle will limit the venturi skimming capabilities.

Included

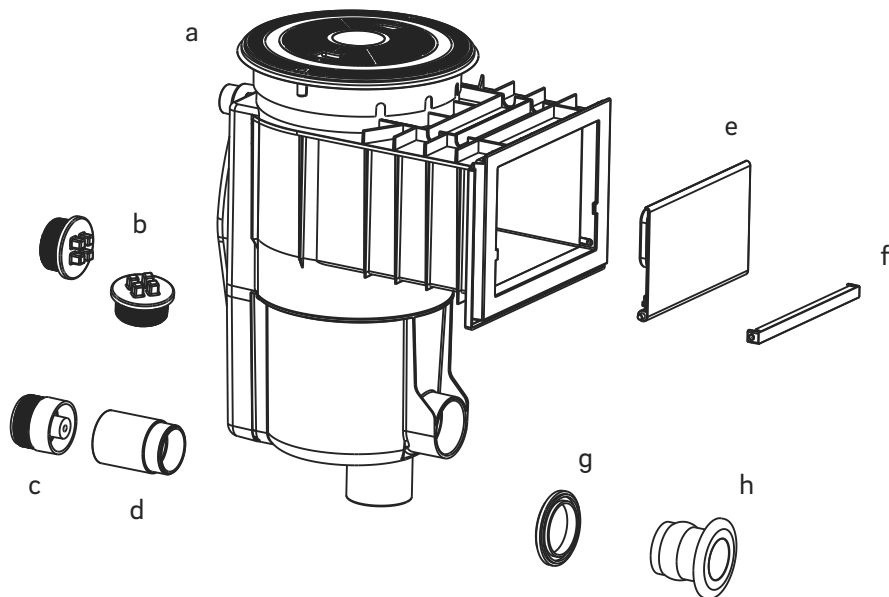

Figure 1

- | | |
|--|--------------------|
| a. QuikSkim (includes lid, basket & silt-sock) | e. Weir |
| b. Threaded 2" plugs w/ O-rings (qty 2) | f. Weir door guard |
| c. Venturi nozzle | g. QuikWaterstop |
| d. Molded 3" diverter | h. QuikGuard |

Installation Procedure

The QuikSkim is designed to operate using venturi technology, which allows more water to circulate through the skimmer than a typical suction line can provide. For this reason, it is not necessary to utilize the suction port required by traditional skimmers while the venturi is in operation. However, in some cases it may be desirable to temporarily utilize the optional suction line for vacuuming and other system maintenance. For this reason, the suction port has been left intact. For more information regarding the preferred setup, refer to the last section titled, Operation.

Locating the QuikSkim

Position and set the QuikSkim using the following image (Figure 2). With the exception of the venturi return port, the QuikSkim can be installed the same as a standard non-venturi skimmer.

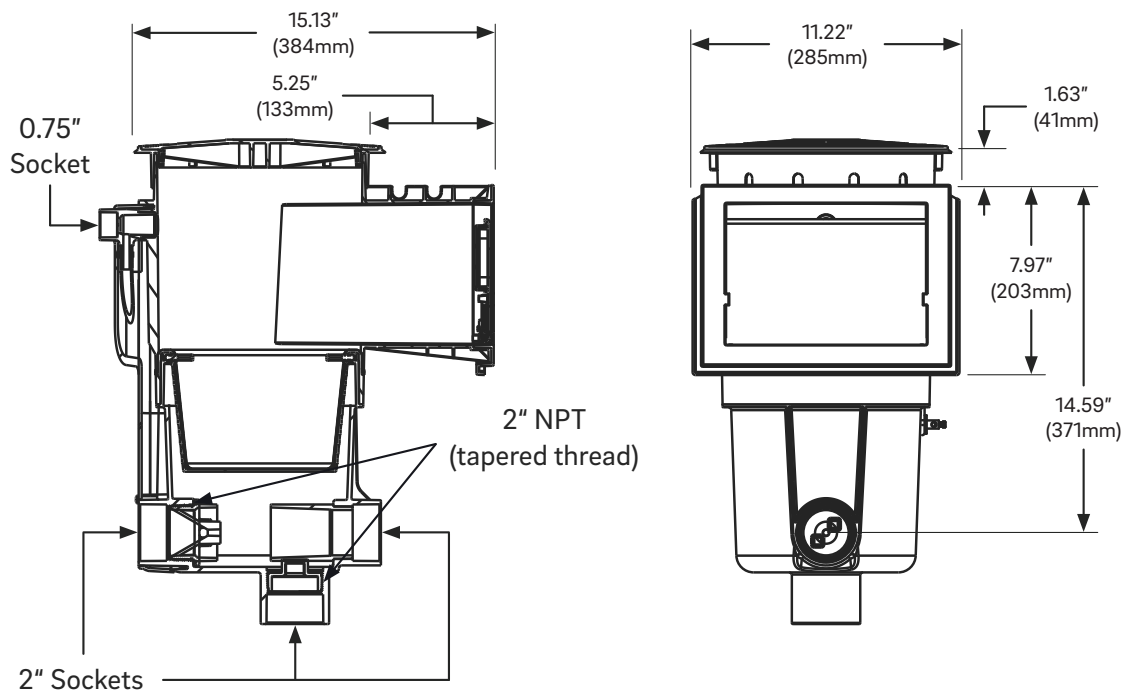

Figure 2

1. Glue an 18 inch length of 2 inch schedule 40 PVC pipe into the discharge port of the QuikSkim located at the lower front, below the mouth of the skimmer. Cap the end to prevent concrete from entering during the shotcrete or gunite process (Figure 3).

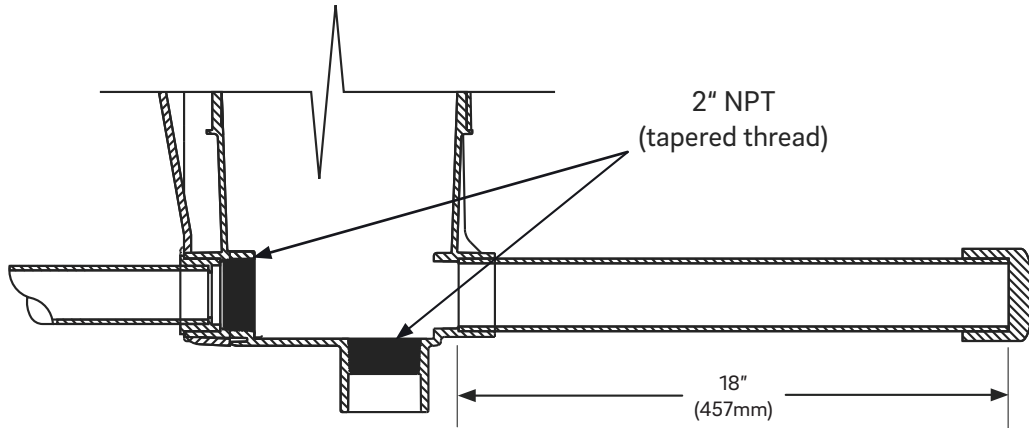

Figure 3

2. To deliver water to the venturi nozzle inside the skimmer, install a Tee fitting on the return line after the filter and before the in-floor valve (Figure 4). Following the branch of the Tee, add a 2-way shut-off valve (Figure 4a) and a minimum of 1 inch schedule 40 PVC (Figure 4b) as the feed line to the QuikSkim's venturi nozzle; reduce the pipe size as needed.

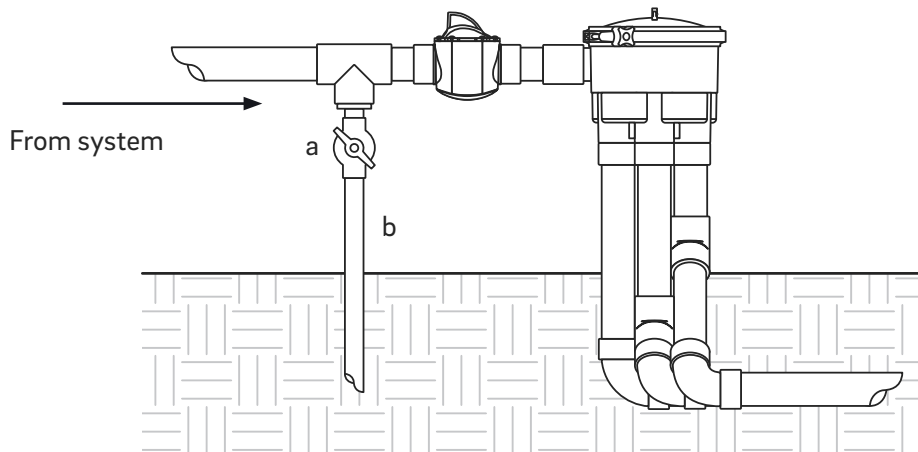

Figure 4

- Bonding can be performed by utilizing the integrated stainless steel bonding lug (optional upgrade) located on the outside of the QuikSkim (Figure 5). The bonding lug is molded into the body and connects to a corrosion resistant 316 stainless steel bonding plate (Figure 6b) located on the inside of the skimmer. However, in the event that this plate should ever become corroded, it can easily be replaced by loosening the stainless steel locking nut (Figure 6a), removing the old bonding plate, adding a new bonding plate and resealing the locking nut.

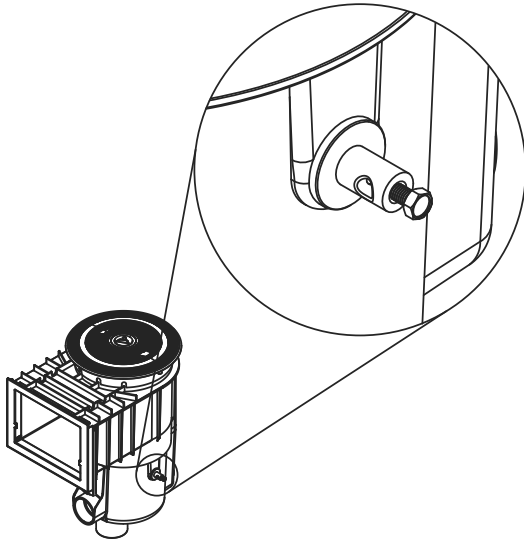

Figure 5

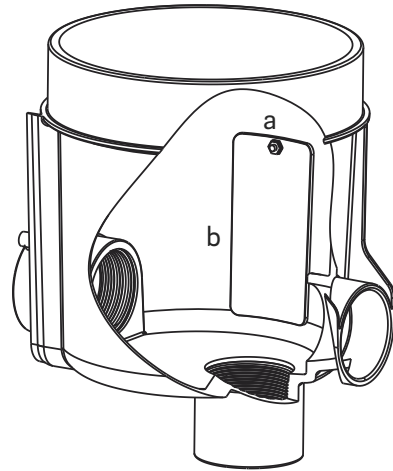

Figure 6

- After the concrete has been shot and before it has set, be sure to clear away a space approximately the width of two fingers around the perimeter and behind the waterstop (Figure 7). This will ensure enough area is available to properly dry-pack the void and prevent leaking. The newly designed waterstop provides better protection against leaks, while making it easier to properly install tile of any size.

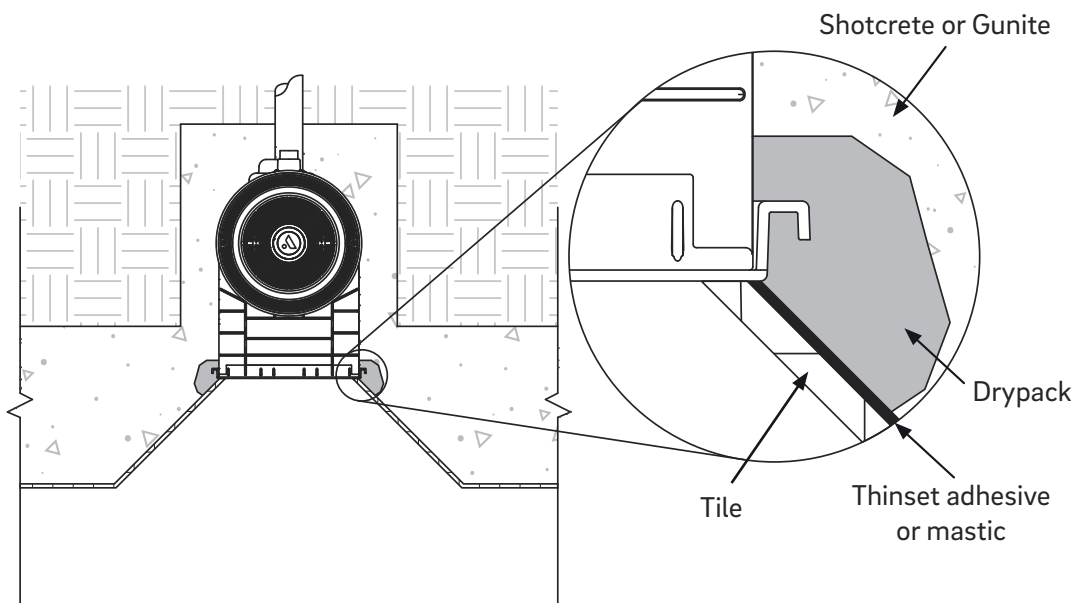

Figure 7

- Once the shotcrete is complete, cut the capped pipe that was installed on the venturi discharge line (Figure 3) so that it will be flush with the finished surface. Glue the pipe and slide the QuikWaterstop (Figure 9c) over the pipe and allow enough room to dry-pack behind it to ensure a waterproof seal (Figure 8).

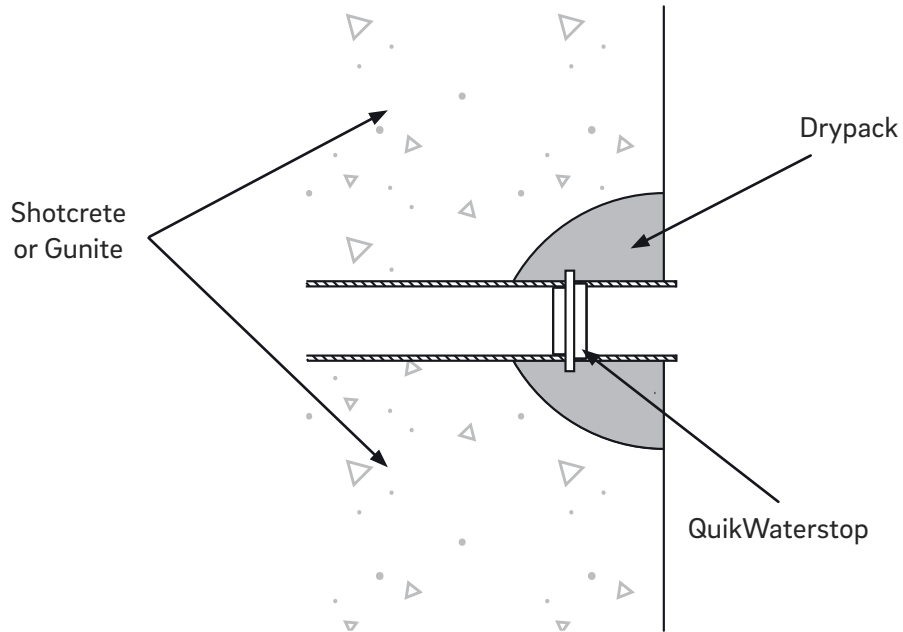

Figure 8

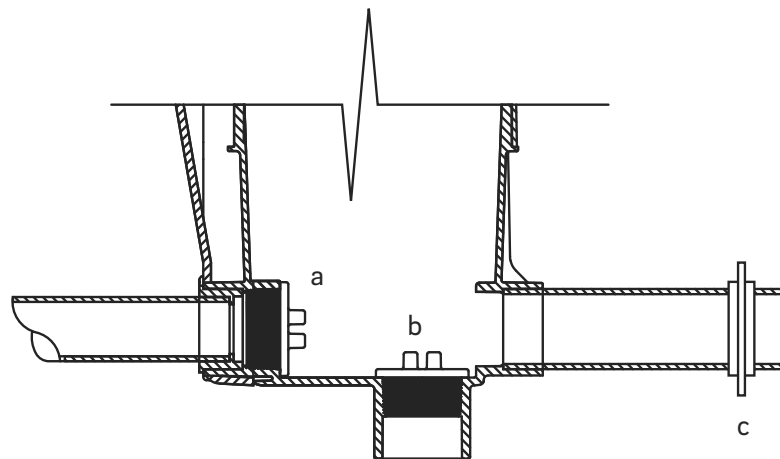

Figure 9

- Install the included 2" threaded plugs from the inside of the skimmer; one into the venturi inlet on the back side (Figure 9a) and one into the suction port at the bottom (Figure 9b). One of three approved methods for installing and removing the included test plugs can be used. Under no circumstances should silicon sealant or pipe dope be used on the threads.

METHOD 1: use a 1-5/8" (41.28mm), 12-point socket (not a 6-point socket) with a 1/2" ratchet drive (an extension may be required) (Figure 10).

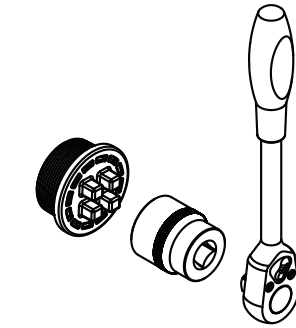
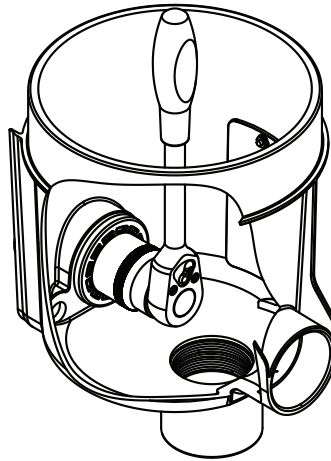
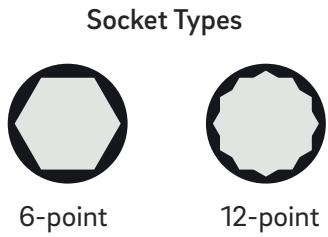

Figure 10

METHOD 2: use the QuikSkim plug removal tool with a 1/2" ratchet drive (an extension may be required) (Figure 11).

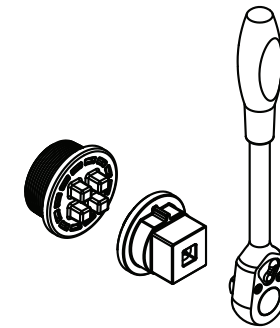
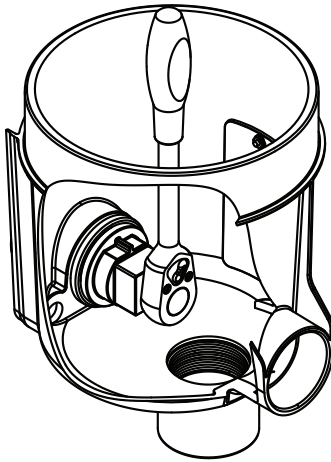

Figure 11

METHOD 3: use the QuikSkim plug removal tool with the original QuikSkim removal tool (Figure 12).

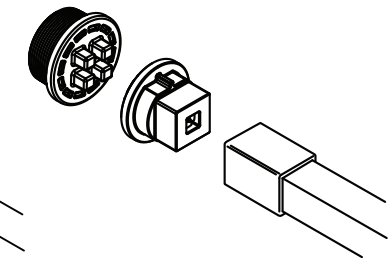
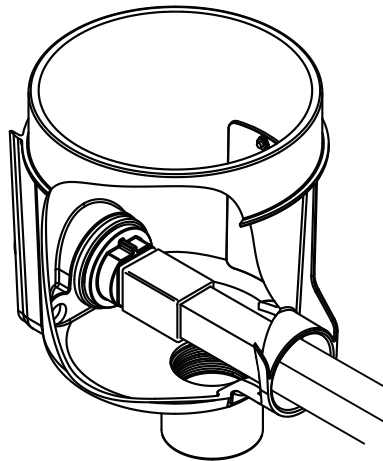

Figure 12

- After applying the finished surface, install the QuikGuard "knock-In" wall fitting (Figure 13a) and remove the weir door guard (Figure 13b). Install weir at startup.

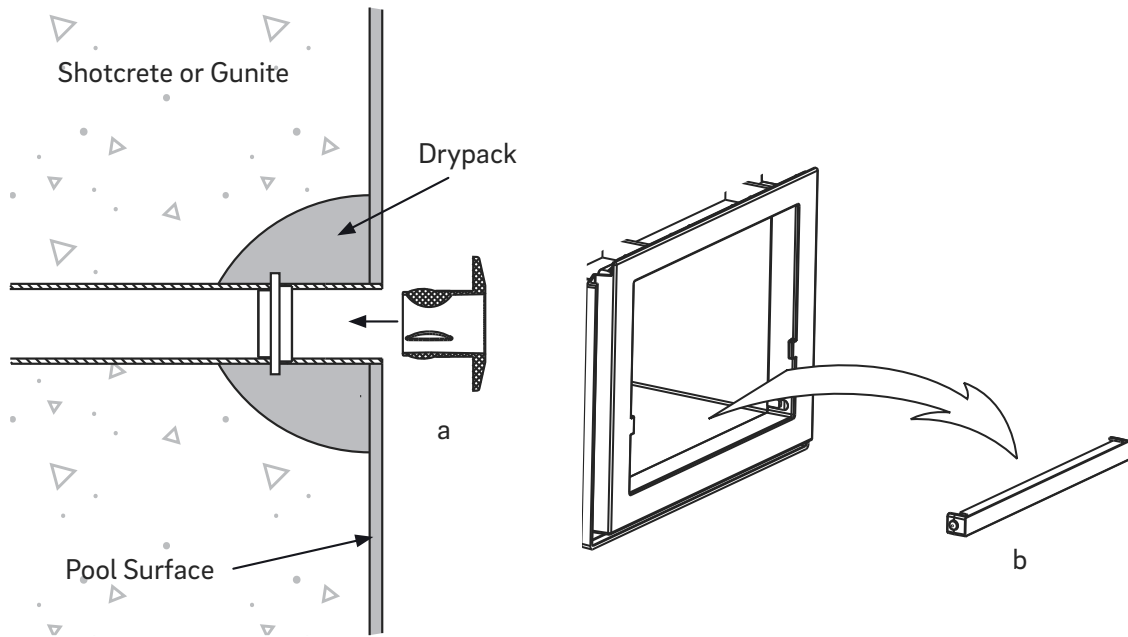

Figure 13

- At start-up, remove the pressure testing plugs inside the skimmer and install venturi nozzle into the venturi inlet. The venturi inlet is located on the bottom rear of the skimmer (Figure 14a).
- Install the weir into the mouth of the skimmer.
- Push the provided 3" molded sleeve into the discharge port directly opposite the venturi nozzle (Figure 14b). This sleeve must remain unglued, so that it can be removed in the future for vacuuming, pressurization or to winterize the system.

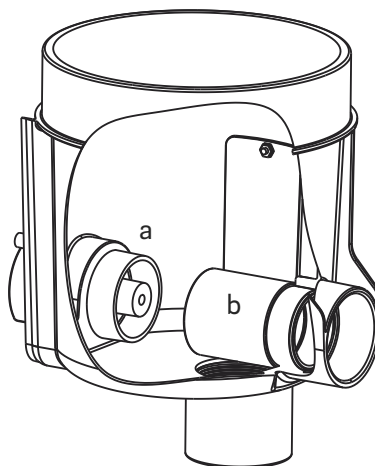

Figure 14



Operation

Basket and Silt-sock

The QuikSkim comes with a silt-sock that can be used inside of the basket or removed if it is not needed.

1. Removing the silt-sock is easy. Begin by rolling up the edge of the silt-sock from around the top of the basket until it comes around the basket handle (Figure 15a).

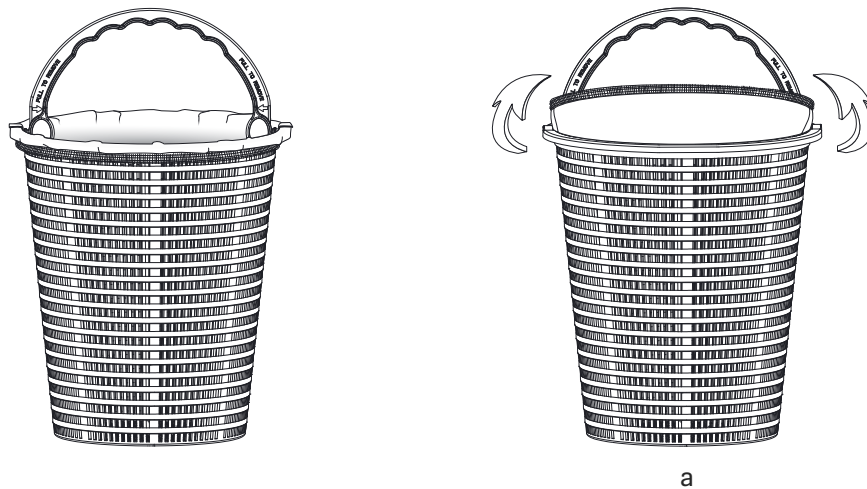

Figure 15

2. Hold the side of the basket handle to pull the handle pin away from the basket slot until it is removed from the slot (Figure 16a) and repeat this procedure on the other side of the handle until the handle and silt-sock are free to remove from the basket (Figure 16b).

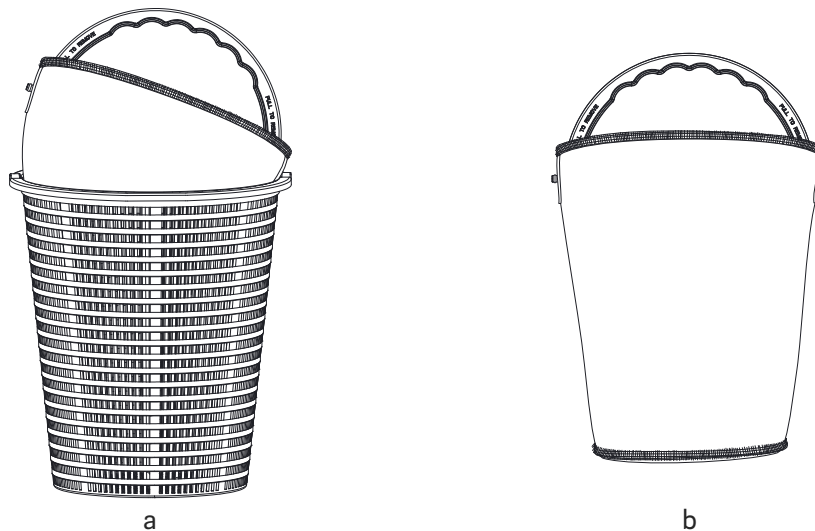

Figure 16

3. Once the handle is separated from the basket (Figure 17a), the silt-sock can be removed and emptied. A garden hose may be required to spray off any fine debris that may be caught in the fine mesh.

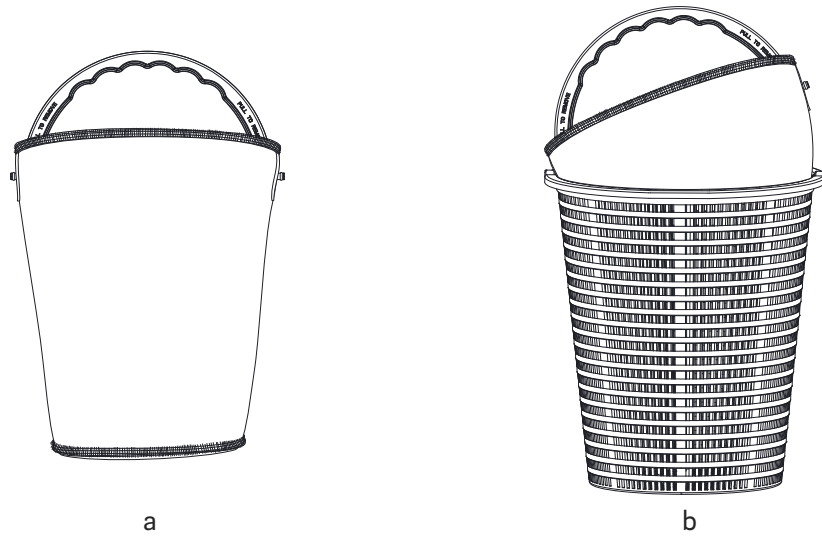

Figure 17

4. To reinstall the silt-sock into the basket, locate the manufactured holes in the silt-sock and push the handle pins into each hole and then begin to insert the pins into the basket (Figure 17b). Once complete, roll the silt-sock over the basket lip (Figure 18a).

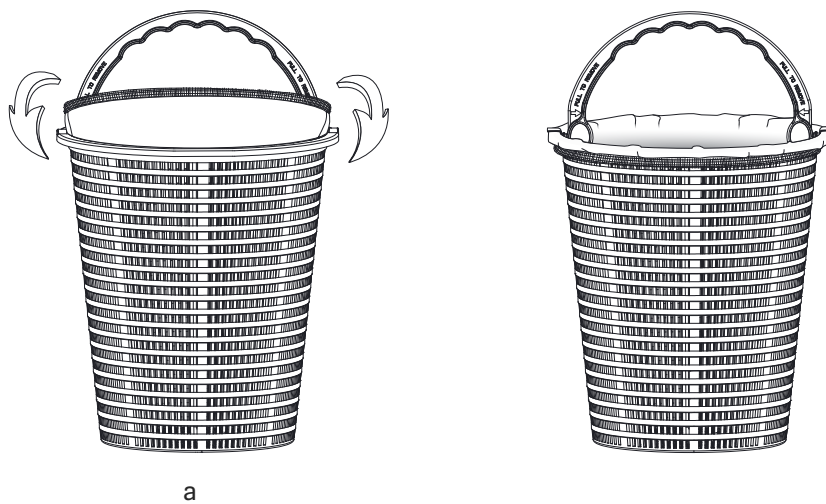

Figure 18

Venturi Setup

Proper flow to the venturi nozzle can be set by adjusting the shut-off valve installed before the water-valve (Figure 4).

When the QuikSkim is installed on a pool that is setup using the venturi, the suction should be diverted so that all of the suction is pulled through the main-drain and none of the suction is pulled from the skimmer (Figure 19). This arrangement will result in the main-drain providing maximum debris removal from the bottom of the pool, while the QuikSkim venturi skimmer provides maximum debris removal from the surface, without sacrificing suction by sharing with the main-drain.

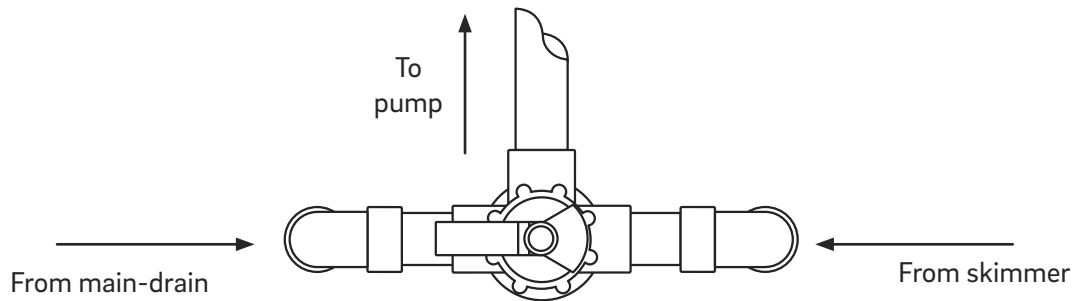

Figure 19

Standard Suction Setup

Shut off flow to the venturi line completely by closing the shut-off valve installed on the return line before the water-valve (Figure 4).

When the QuikSkim is used as a standard skimmer, the suction should be diverted so that the line from the main-drain is shut about half way and the suction line from the skimmer is completely open (Figure 20). This arrangement will result in the skimmer suction pulling debris from the surface of the water before sinking to the bottom of the pool. Additionally,

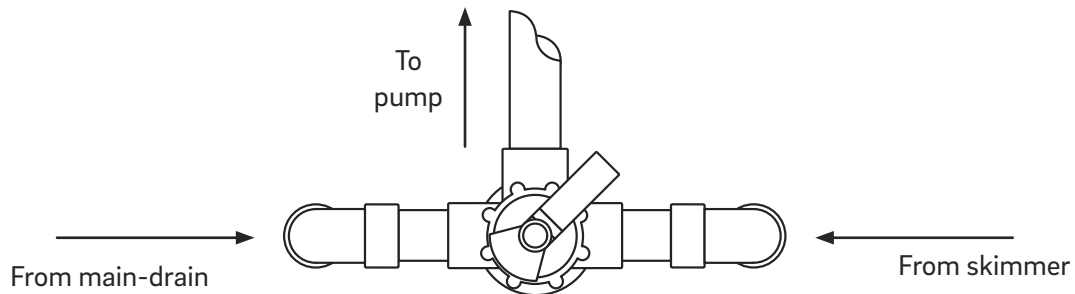

Figure 20

Winterization Setup

1. In order to evacuate the lines during the winterization process it is recommended that a 2-Way shut-off valve be installed on each suction branch-line preceding the main line feeding the pump (Figure 21).

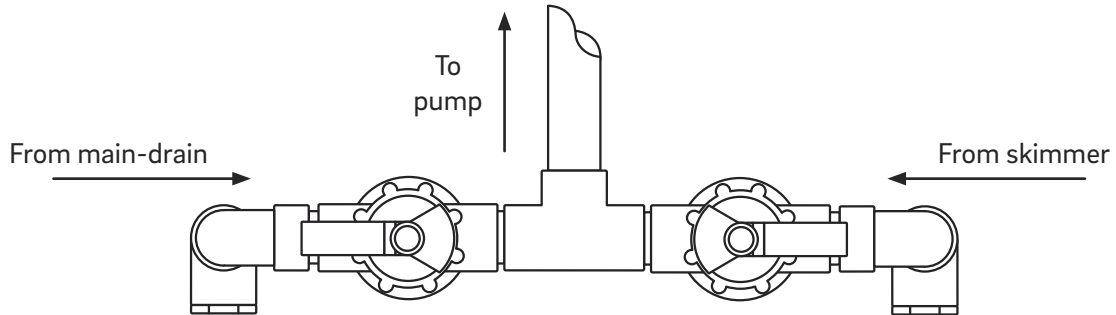

Figure 21

2. Between the 2-Way shut-off valve and the drain, install a Tee fitting with a 2 inch threaded branch. This will allow a 2 inch threaded plug to be removed later during the winterization process (Figure 22).

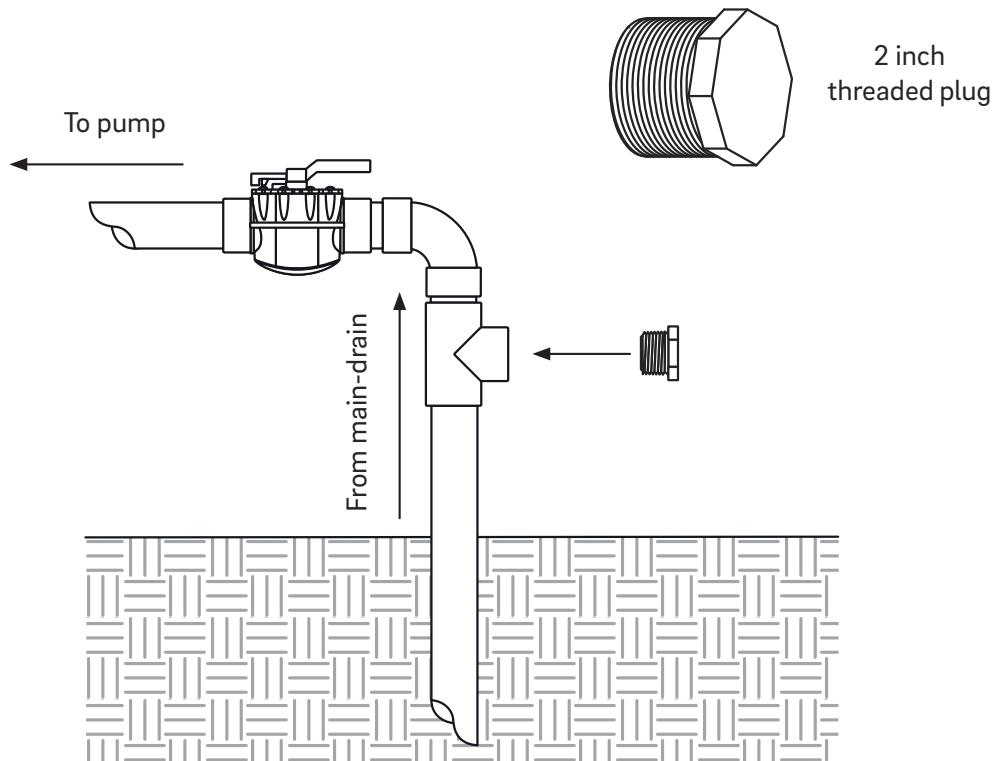

Figure 22

3. Ensure the suction line coming from QuikSkim is shut off.
4. Remove the 2 inch threaded plug (Figure 22) and replace it with a 2 inch thread by 1.5 inch slip reducer bushing (Figure 23).
5. Install and secure a plug containing an air valve into the 1.5 inch slip portion of the reducer bushing.
6. With the skimmer valve closed, blow out the skimmer line for a minimum of 30 seconds. This will provide an airlock in the line and prevent water from freezing in the pipe.

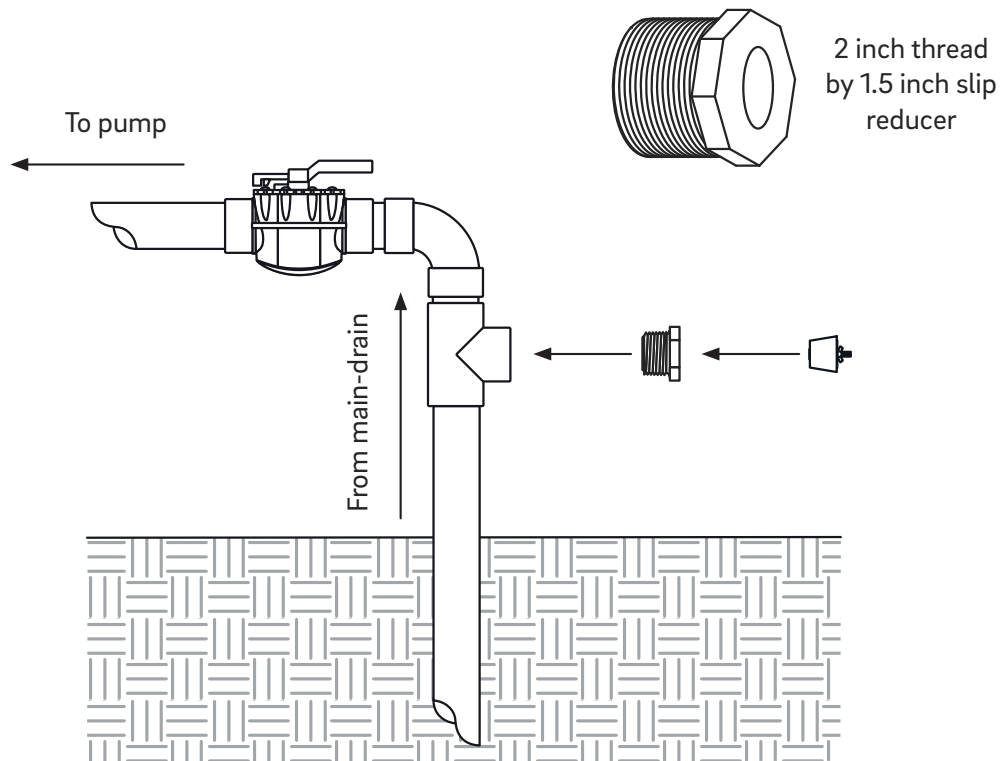

Figure 23



Limited Warranty

To original purchasers of this equipment, A&A Manufacturing will warrant the QuikSkim from defects in materials and workmanship for a period of one year from the date of purchase.

The limited warranty excludes damage from freezing, negligence, improper installation, improper use or care or any Acts of God. Parts that fail or become defective during the warranty period shall be repaired or replaced, at A&A Manufacturing's option, within 90 days of the receipt of defective product, barring unforeseen delays, without charge. Proof of purchase is required for warranty service. In the event proof of purchase is not available, the manufacturing date of the product will be the sole determination of the purchase date. To obtain warranty service, please contact the place of purchase. A&A Manufacturing shall not be responsible for cartage, removal, repair or installation labor or any other such costs incurred in obtaining warranty replacements or repair.

The A&A Manufacturing warranty does not apply to components manufactured by others. For such products, the warranty established by the respective manufacturer will apply. The express limited warranty above constitutes the entire warranty of A&A Manufacturing with respect to its pool products and is in lieu of all other warranties expressed or implied, including warranties of merchantability or fitness for a particular purpose. In no event shall A&A Manufacturing be responsible for any consequential, special or incidental damages of any nature.

Please retain for your records.

Date of Installation _____



A&A Manufacturing

QuikSkim Warranty Registration Card

Directions: Please Fill out bottom portion completely and mail within 30 days of purchase or register your product online at www.amfg.com

Please Mail to:
ATTN: WARRANTY DEPT,
A&A Manufacturing
3750 W Indian School Dr, Phoenix AZ 85019

PLEASE PRINT CLEARLY

Owner Information

First Name _____ Last Name _____

Street Address _____

City _____ State _____ Zip _____

Phone Number _____ Purchase Date _____

E-Mail Address _____

Product Model Number _____

Original Purchase Information

Company Name _____

Address _____

City _____ State _____ Zip _____

Phone Number _____