

AVSC[®] HEAVY
DEBRIS
REMOVAL

Installation Instructions & User Guide



A&A Manufacturing

Rev. 20210218

© Copyright 2021 A&A Manufacturing. All rights reserved

Page Left Blank



Table of Contents

Prior to Installation	1
Safety Information	1
Components	3
Dimensions	4
Specifications	5
Installation Life	5
Certified Part Numbers	5
Head Loss Curves	6
AVSC Dimensions	7
Installation	9
Locating the Return in the Floor	9
Hydrostatic Valve (optional)	11
Locating the Return on the Wall	12
Split Drain	14
Steel and Concrete	15
Finished Surface	16
Equipment Plumbing	17
Standard Setup	17
QuikSkim and QuikSkim-Ultra Setup	17
Winterization Setup	18
Limited Warranty	20
Warranty Card	21

SAVE THESE INSTRUCTIONS

IMPORTANT

The AVSC Drain is classified as an 'Unblockable SOFA.' According to Section 1404 (b) of the Virginia Graeme Baker Pool & Spa Safety Act (VGB-2008), ASME/ANSI A112.19.8-2007, ANSI/APSP-16-2011, ANSI/APSP/ICC-16 2017 standards and safety regulation 16CFR 1450 Virginia Graeme Baker Pool and Spa Safety Act Regulations set forth by the Consumer Product Safety Commission, and therefore does not require an SVRS (Suction Vacuum Release System) as set for by ANSI A112.19.17.

Testing for this SOFA was performed by IAPMO R&T Lab, Ontario, CA, October 2020



Prior to Installation

IMPORTANT SAFETY INSTRUCTIONS

Read, Follow, and Understand All Warnings and Instructions



WARNING

Before installing this product, installers, pool operators and pool owners must read and understand all warnings and safety precautions set forth on pages 1-2 of this installation guide.



WARNING

This SOFA must be installed by a licensed or certified plumber or a qualified pool professional adhering to all applicable Federal, State and local codes and ordinances.



WARNING

Install this SOFA in accordance with the instructions provided. NEVER install this SOFA in a seat or backrest area. Use only with the components and mounting hardware provided. Failure to adhere to the following instructions or use components other than the ones provided, may result in severe personal injury or death.



WARNING

No modifications, adaptations or alterations shall be made to the structure or flow path of this SOFA. Any changes are strictly prohibited and will void the SOFA certification and product warranty.



WARNING

All SOFA components shall be replaced at or before the end of their service life. The designated service life begins the month and year in which a SOFA component is installed, with or without water.



WARNING

The drain covers and all other SOFA components, including fasteners, should be observed for damage or tampering each operational day and replaced if cracked, brittle with chunks or pieces missing, stripped, damaged, having loose or missing screws and screw-bosses. The pool MUST be shut down immediately until the damaged items can be replaced.



WARNING

The design flow rate of the pool and spa should be less than or equal to the maximum flow rate indicated on the cover by the manufacturer. The use of covers other than those listed in this document or allowing use of a pool or spa when covers are cracked or broken may result in severe personal injury or death.



WARNING

DO NOT OVERTIGHTEN THE FASTENERS. The fasteners should never exceed a maximum torque of 15 inch-pounds. Overtightening the fasteners could cause cover or sump to become cracked or broken, which may result in severe personal injury or death.



WARNING

The use of adhesives or other attachment methods that prevent access to suction piping or SOFA components requiring periodic servicing is prohibited.



WARNING

DO NOT attempt to repair stripped, loose or damaged screws or screw bosses. The pool MUST be shut down immediately until the SOFA components containing these items are replaced.



WARNING

Only use the 316 stainless steel T20 screws provided. Substitute screws such as masonry screws, sheet rock screws or other types of screws should never be used, will cause the cover to come loose and could result in limb or body entrapment, hair entanglement or evisceration/ dismemberment.



WARNING

If the face ring, sump, screw or screw holes are damaged in any way that prevents complete insertion of the specified screw, the face ring, sump or damaged screw must be replaced. Do not attempt to modify or alter any components in any way.



ATTENTION

This SOFA is an UNBLOCKABLE VGBA Suction Outlet that may be installed as a single VGBA Suction Outlet system.



ATTENTION

The flow rating for pools with a single, or multiple unblockable SOFAs shall be determined by combining the flow rating of all SOFAs piped together in one body of water.



ATTENTION

DO NOT USE POWER TOOLS TO INSTALL FASTENERS. Always install the cover screws by hand to ensure proper thread engagement and to prevent cross threading. When the fasteners have been installed ALWAYS hand-check the cover for snugness to ensure it is properly secured to the sump.



ATTENTION

Always check SOFA components and make sure the fastener receptacles are clean and free of debris or obstructions during installation of cover and fasteners.



ATTENTION

Loose covers shall be reattached before bathers are allowed to use the pool.



ATTENTION

Use only ABS to PVC solvent when making PVC plumbing connections to the AVSC sump.



ATTENTION

Do not use hydraulic cement. The heat generated during the curing process may damage or warp the sump.

Components

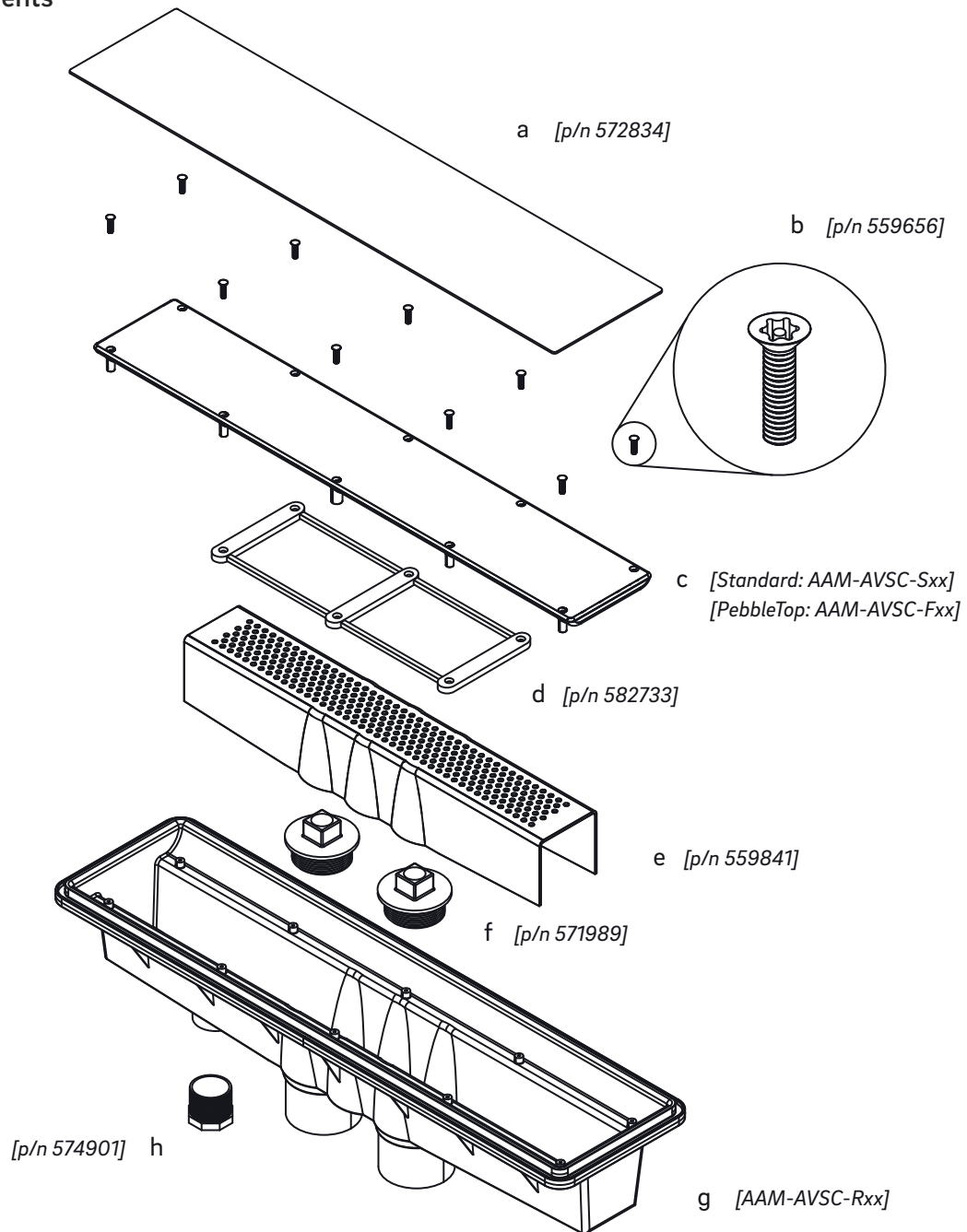

Figure 1

- | | |
|---|--|
| a. Construction cover (disposable) | e. Baffle w/ adhesion packet |
| b. 1-3/8", 316 stainless steel, Torx No.20 tamper-proof (qty. 10) | f. Pressure testing plugs, including O-rings (factory installed) |
| c. Standard cover (PebbleTop cover optional) | g. Sump (dual-port shown) |
| d. Anti-warp bar (disposable) | h. Hydrostatic port plug (hydrostatic valve optional) |

AVSC Dimensions

The total effective suction area of the AVSC channel drain has been certified as 77.59 in² (1971 mm²).

The ACSV drain suction ports are glue fittings that can be connected using either a 3" fitting on the outside or 2.5" pipe on the inside.

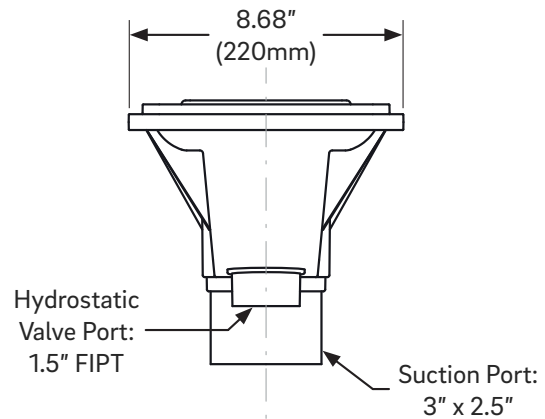

Figure 2

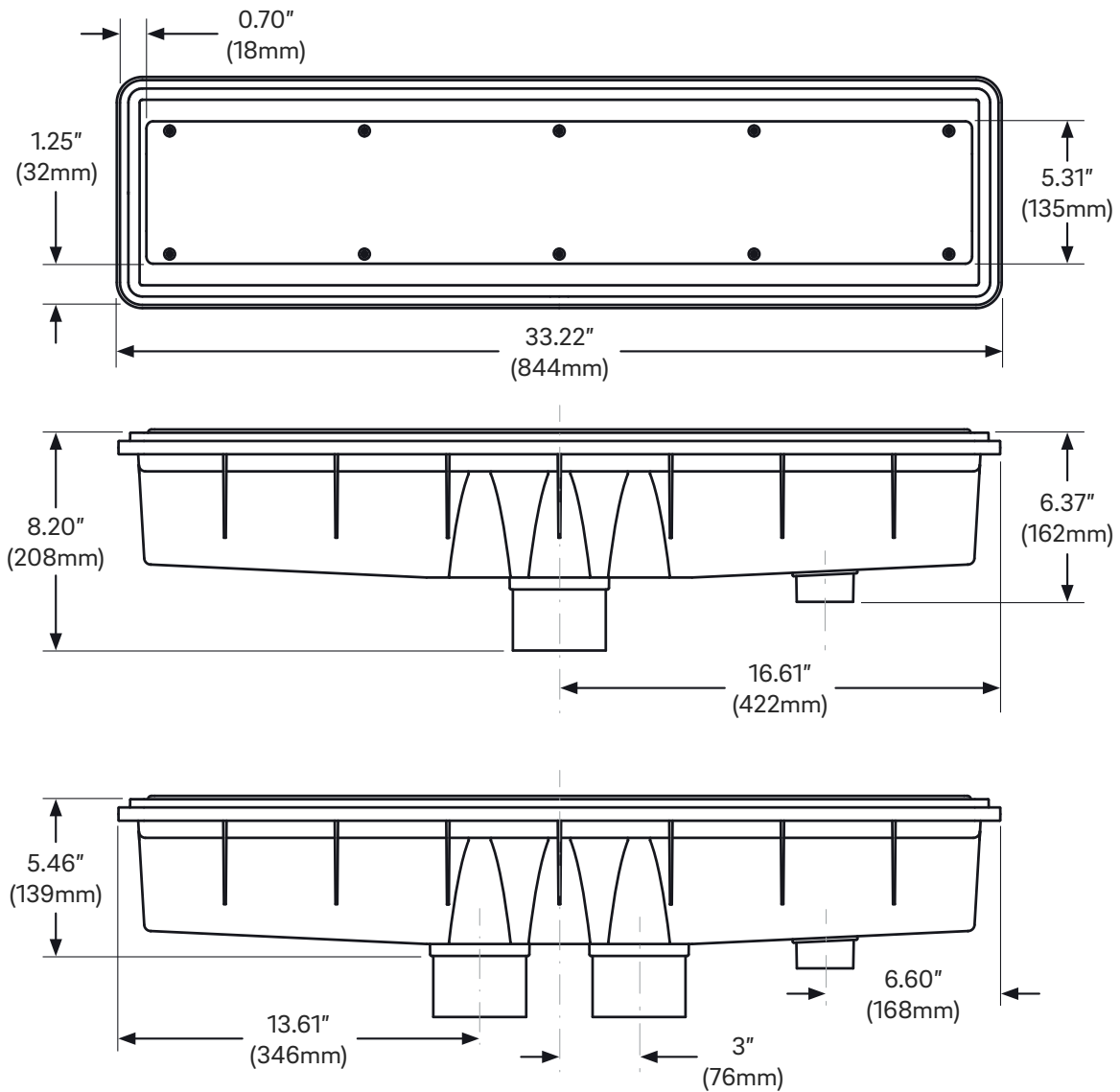

Figure 3

Specifications



Standard Cover

	2.5" pipe		3.0" pipe
FLOOR	237 gpm (single)	237 gpm (dual)	302 gpm (single & dual)
WALL	167 gpm (single)	184 gpm (dual)	302 gpm (single & dual)

PebbleTop Cover

	2.5" pipe		3.0" pipe
FLOOR	237 gpm (single)	237 gpm (dual)	302 gpm (single & dual)
WALL	184 gpm (single)	184 gpm (dual)	302 gpm (single & dual)

Return Methods & Installation Life

Depending on the desired placement, the AVSC drain has been certified as either a floor or wall return. Please follow the specifications above to identify which cover style is appropriate for the intended application.

Both Standard and PebbleTop covers for the AVSC drain have been certified for a maximum period of seven (7) years from the installation date. Upon the expiration of this designated period, the drain cover must be replaced. The sump has been certified for a period of 30 years. This is intended remain for the life of the structure in which it is installed. However, if at any point the sump becomes cracked or damaged, it is mandatory that the pool be shut down and all damaged components be removed and replace immediately. The installation life and installation date are stated on the Certificate of Compliance for the AVSC drain and will be provided by the installer.

If the cover exhibits any unnatural wear or extreme discoloration within its maximum lifespan the pool MUST be closed and the cover replaced, before bathers are allowed to reenter the pool.

Certified Part Numbers

"XX" denotes the color number code.

Standard Cover: AAM-AVSC-SXX
PebbleTop Cover: AAM-AVSC-FXX
Sump: AAM-AVSC-RXX

Color Number Codes

White - 01 Lt. Grey - 02 Grey - 03
 Black - 04 Euro Blue - 05 Blue - 06
 Tan - 07 Gold - 08

The assembly numbers listed below are for ordering purposes only.

	w/ Standard Cover		w/ PebbleTop Cover		Cover only	
	Single	Dual	Single	Dual	Standard	PebbleTop
White	571840	571903	571444	571508	552892	571831
Light Gray	571891	571954	571495	571559	552741	571823
Gray	571858	571911	571452	571516	552905	571815
Black	571866	571920	571461	571524	556121	571786
Gold	571882	571946	571487	571541	556113	571807
Euro Blue	577512	571521	576317	576325	577539	576333
Dark Blue	571874	571938	571479	571532	558803	571794

Head Loss Curves for 2.5" Pipe

Single-Port Sump

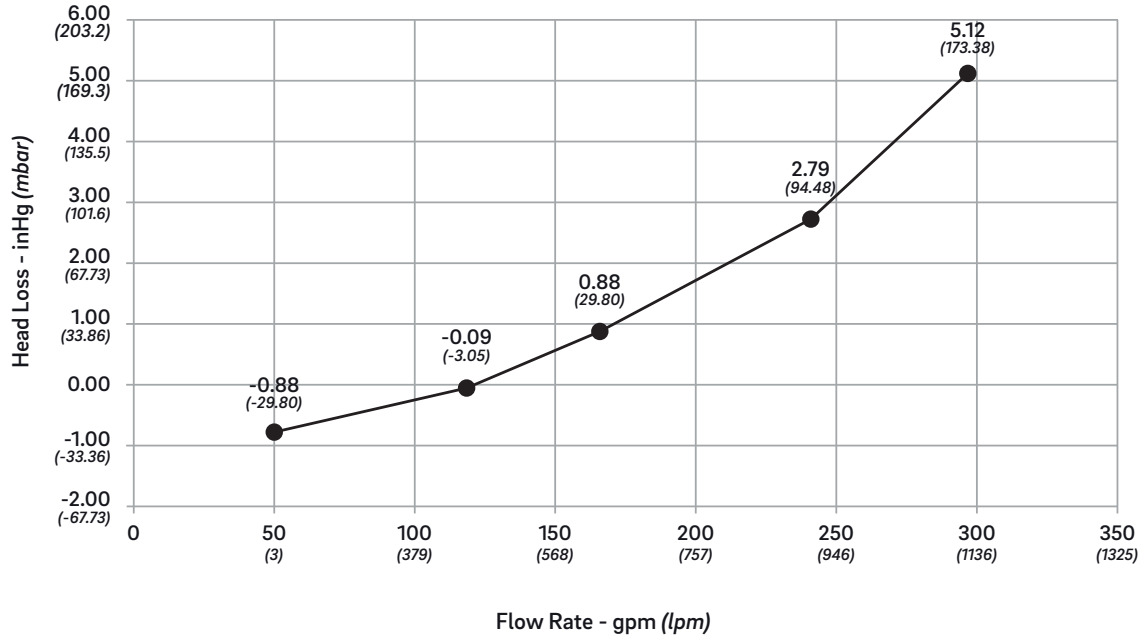

Dual-Port Sump

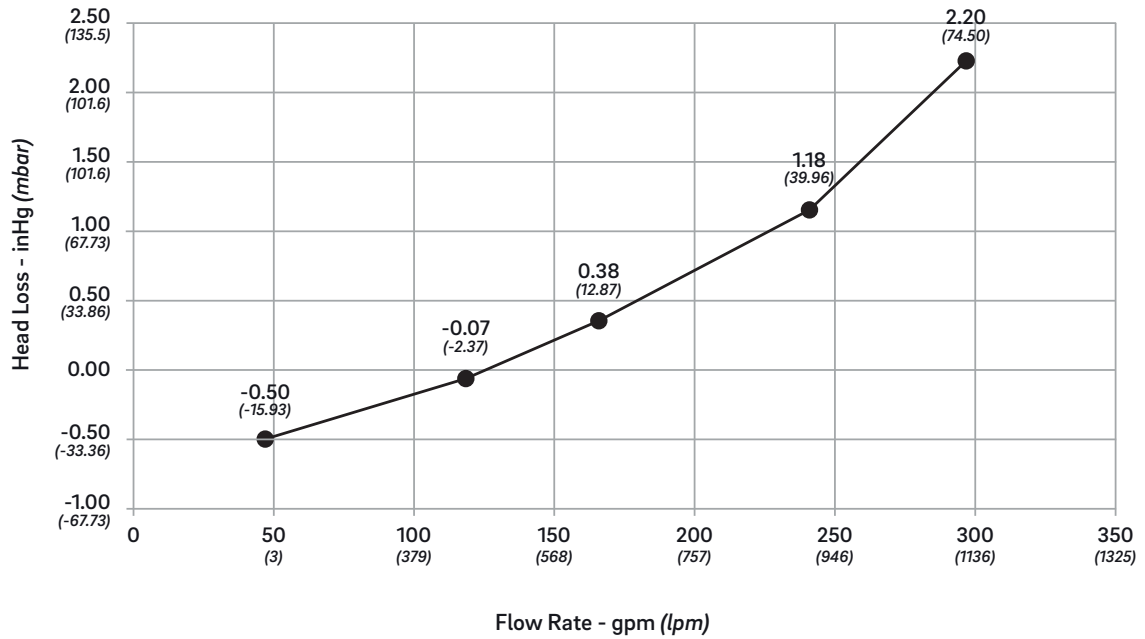

Head Loss Curves for 3.0" Pipe

Single-Port Sump

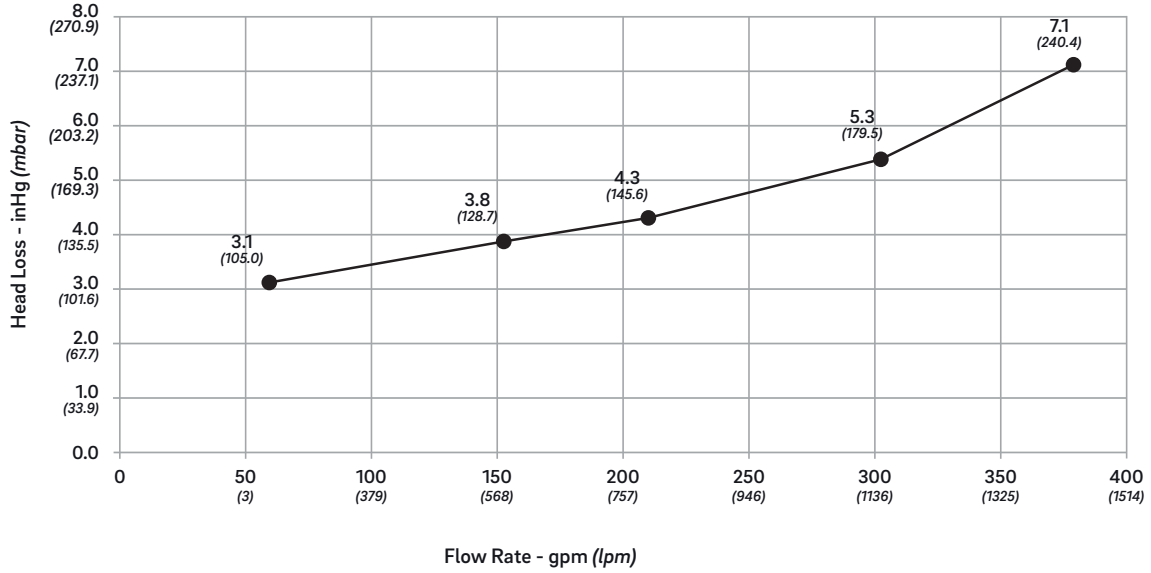

Dual-Port Sump

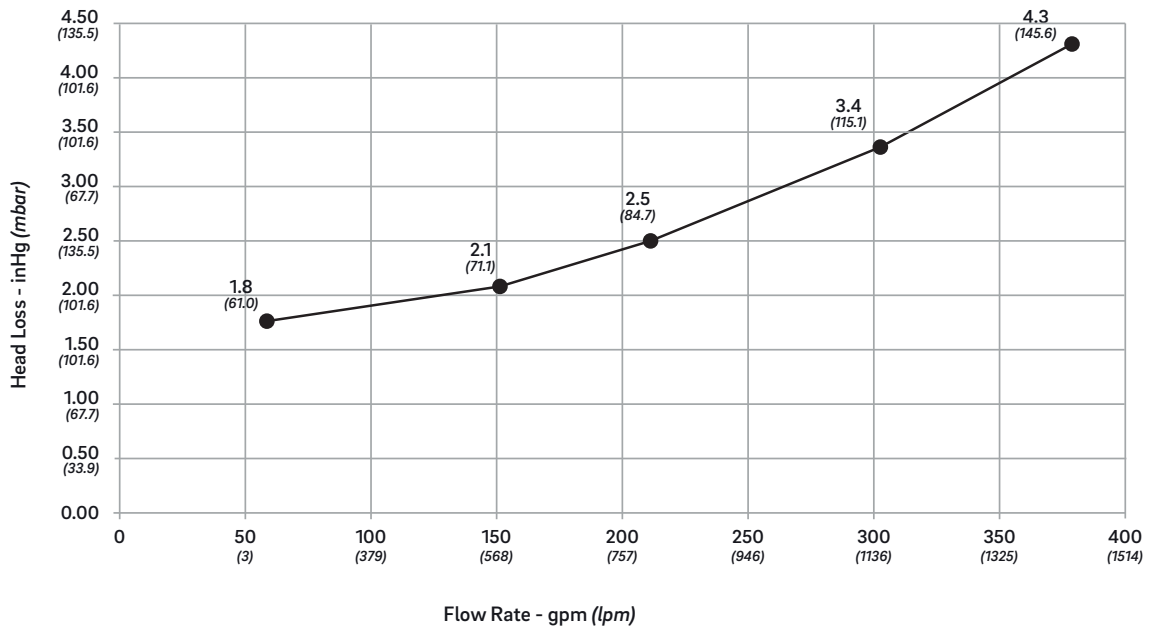



Installation

Locating the Return in the Floor

Since the AVSC drain is installed at the plumbing stage, it is important that the drain be installed directly in the middle of the deepest point of the pool and set at the proper height. The following steps will guide in properly placing the AVSC drain.

1. Run a tight string line across the top of the bond beam forms opposite of each other and directly over the deepest point of the pool. This string line will be used as a reference to locate the proper height of the AVSC drain (Figure 4).

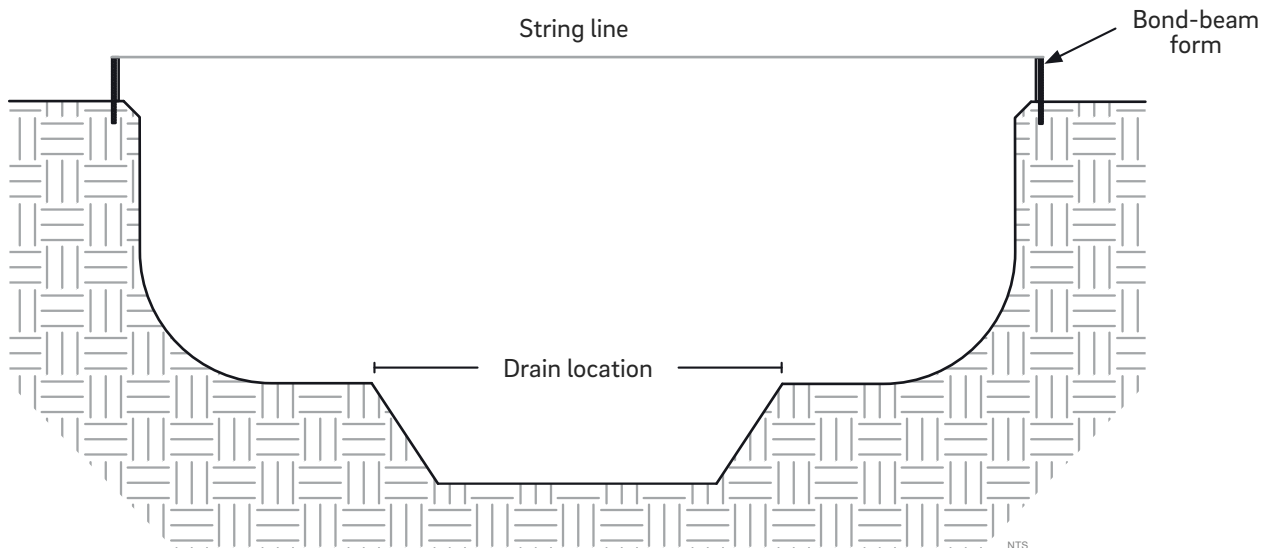

Figure 4

2. Using the suction-line pipe size listed on the A&A Manufacturing Design Sheet, install the main suction line to the point where the AVSC drain will be located.
3. Using the same size pipe as the main suction line, create a riser by cutting a piece of pipe with a minimum length of 18 inches (457mm).

- Using the piece of riser pipe, dry-fit it into one socket of a 90° elbow and glue the other socket onto the end of the main suction that was terminated. In the time it takes the glue to set, use a level against the riser to adjust the 90° elbow to ensure that the riser is vertical on all sides (Figure 5).

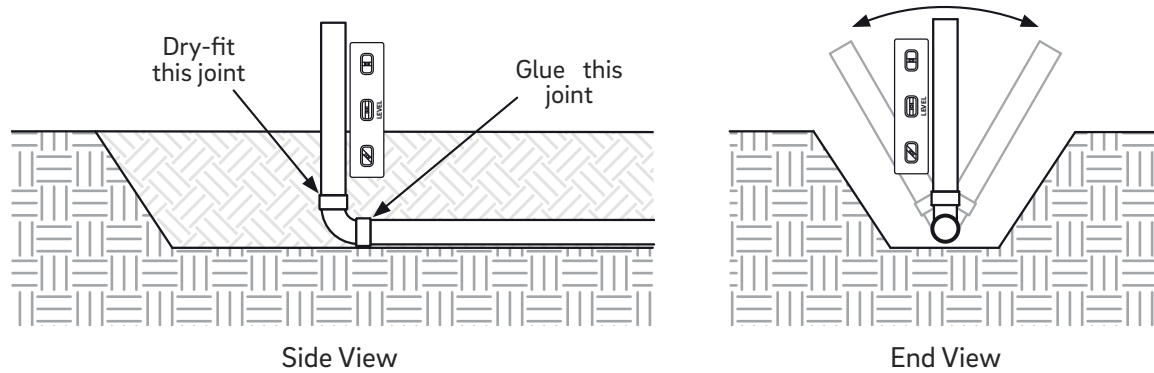

Figure 5

- If a reduction in pipe size is made during the plumbing installation, a minimum distance of 40" (762mm) is required before the reduction can be made (Figure 6). However, it is highly recommended to use the same pipe size or higher for the full run to the pump.

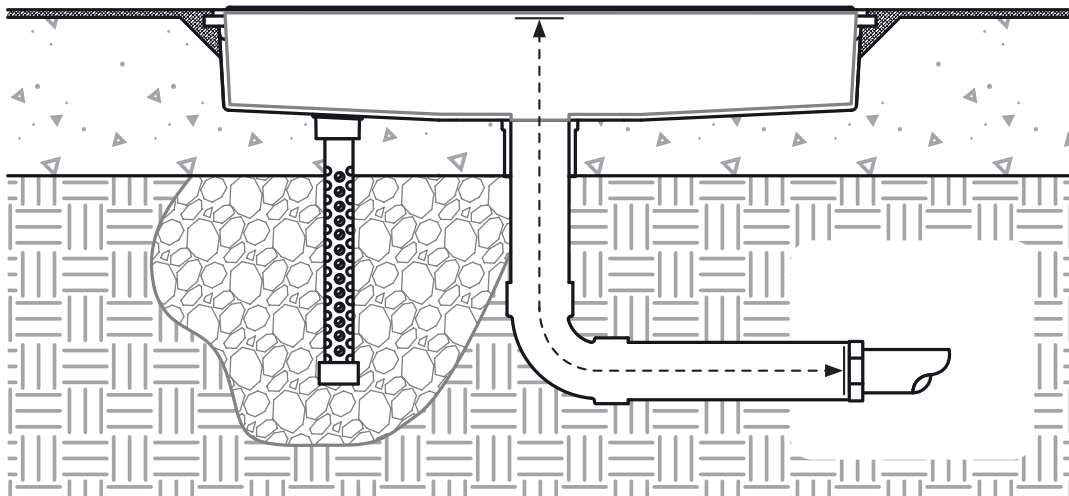

Figure 6

6. After the glued joint on the 90° elbow has set, remove the dry-fit riser from the fitting's socket. Using ABS to PVC glue to connect the riser to the suction fitting on the bottom of the AVSC sump (Figure 7). Once the glue joint between the riser and the sump has fully set, the proper height of the AVSC drain can be set.
7. From the string line that was created in Step 1, measure down the depth of the pool and add 3 inches (76mm). This will be the height of the finished pool surface (Figure 8a). From the height of the finished pool surface, measure down to the bottom of the socket inside the 90° elbow. This will be the total height of the drain and riser (Figure 8b).

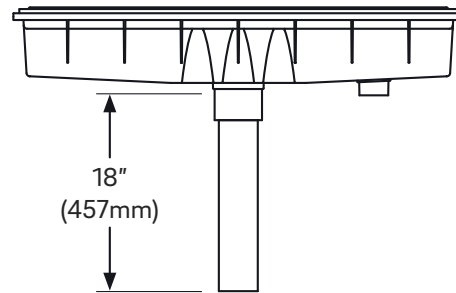

Figure 7

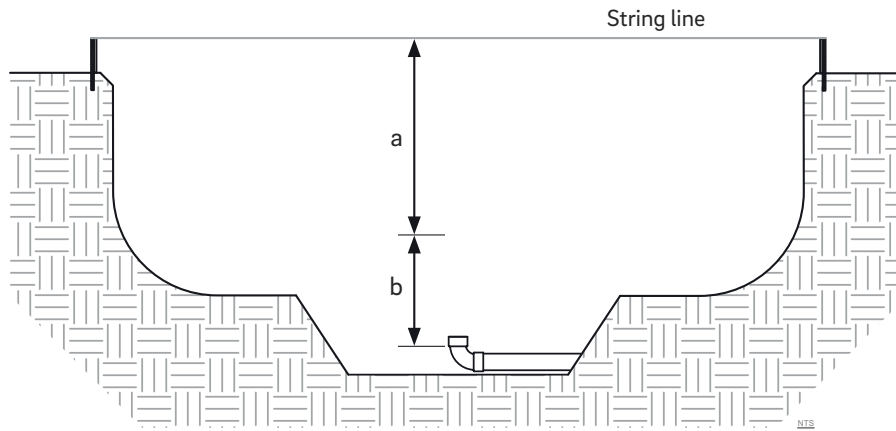

Figure 8

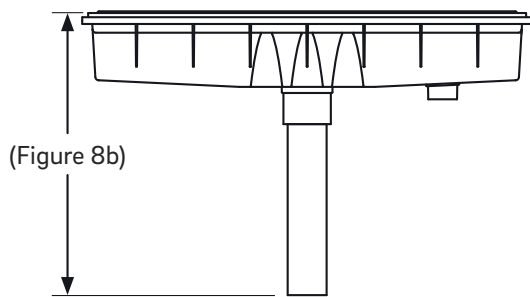

Figure 9

8. From the top edge of the AVSC drain, measure the length of the total height of the drain and riser (Figure 8b) and cut any off any extra length from the riser pipe (Figure 9).
9. The riser can now be glued into the 90° elbow on the main suction line. Once the glue has completely set, the line will be ready to pressurize.

Hydrostatic Valve (optional)

No Hydrostatic Valve:

1. Glue the threads on the plug provided with the AVSC drain and screw it into the small port on the bottom of the drain to ensure a watertight seal (Figure 10).

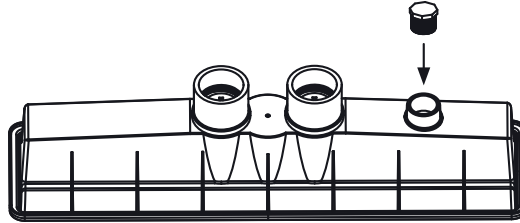

Figure 10

Hydrostatic Valve Used:

1. Begin by creating a collection tube assembly. To do this, cut the perforated collection tube to the desired length and glue a 1.5" cap on one end. On the other end, glue either an 1.5" PVC female adapter (Figure 11a) or use a coupling to attach an 1.5" threaded nipple (Figure 11b).
2. Apply glue to the threads of the collection tube assembly and screw it into the small port on the bottom of the drain.
3. Excavate an area approximately one foot in diameter where the hydrostatic valve will reside once the drain height has been located and the riser has been glued.

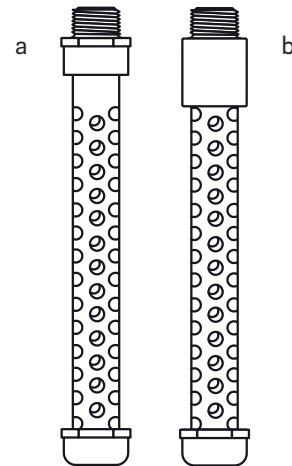

Figure 11

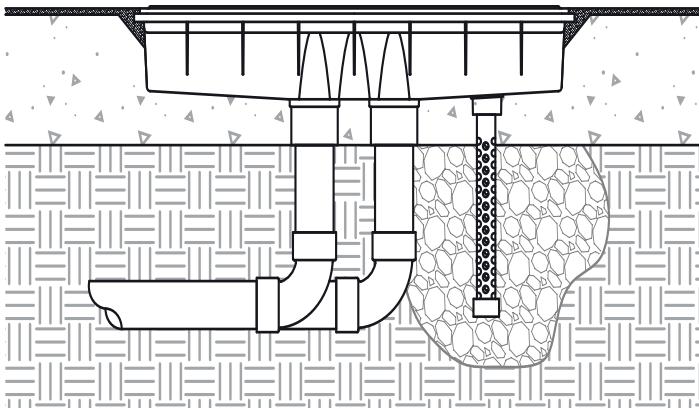

Figure 12

4. Backfill the excavated area with gravel before the shotcrete or gunite process begins. This will ensure less restricted water flow with minimal dirt contamination (Figure 12).
5. Finish by installing an 1.5" hydrostatic valve inside the sump, through the top side of the AVSC drain.

Locating the Return on the Wall

1. The AVSC drain is to be located midway down the wall, in-line with the deepest part of the pool. The bottom of the 90° elbow feeding the drain from the main suction line, must be a minimum of 18 inches above the top of any cove, and the upper edge of the drain sump must be placed at least 12 inches below the bond beam form (Figure 13).
2. Maintain a plumb line 12 inches away from the front of the bond beam form toward the center of the pool. This line will represent the finished surface of the wall (Figure 13).

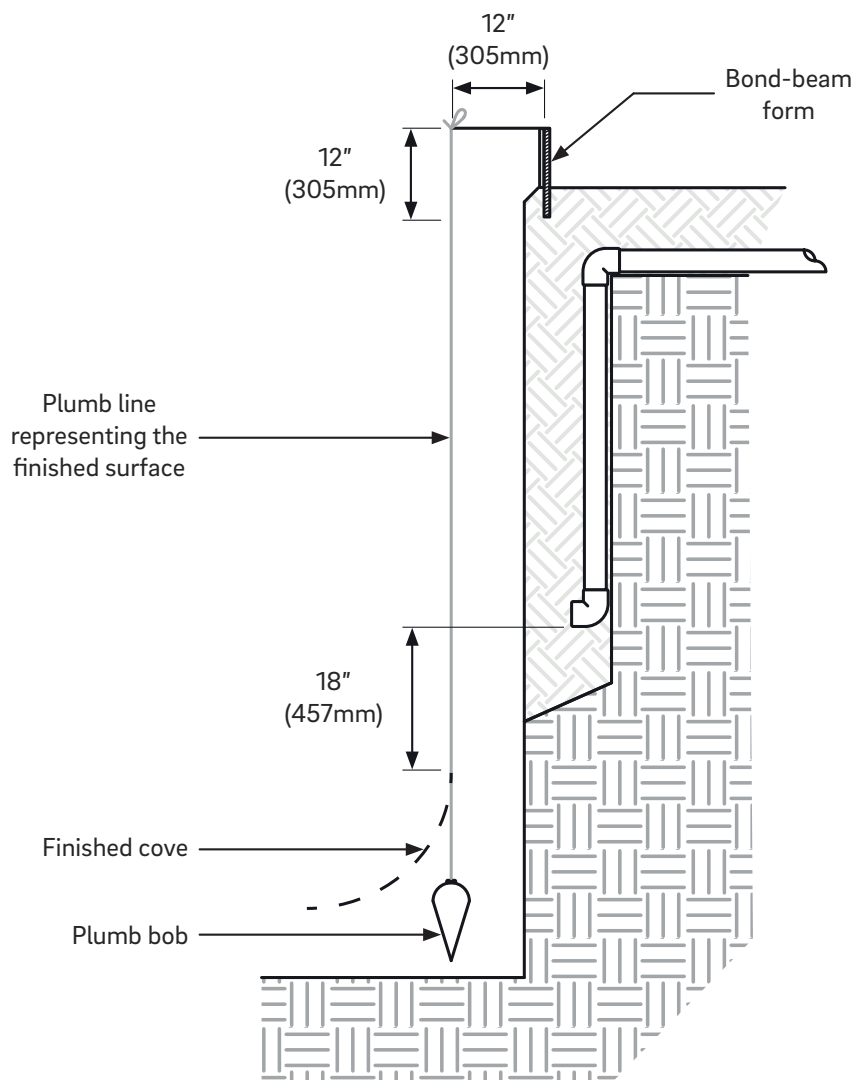

Figure 13

3. Dig a niche down the wall of the pool at the desired location of the AVSC drain. The niche must be at least 12 inches wide (Figure 14) for a vertical alignment and at least 36 inches wide (Figure 15) for horizontal alignment.

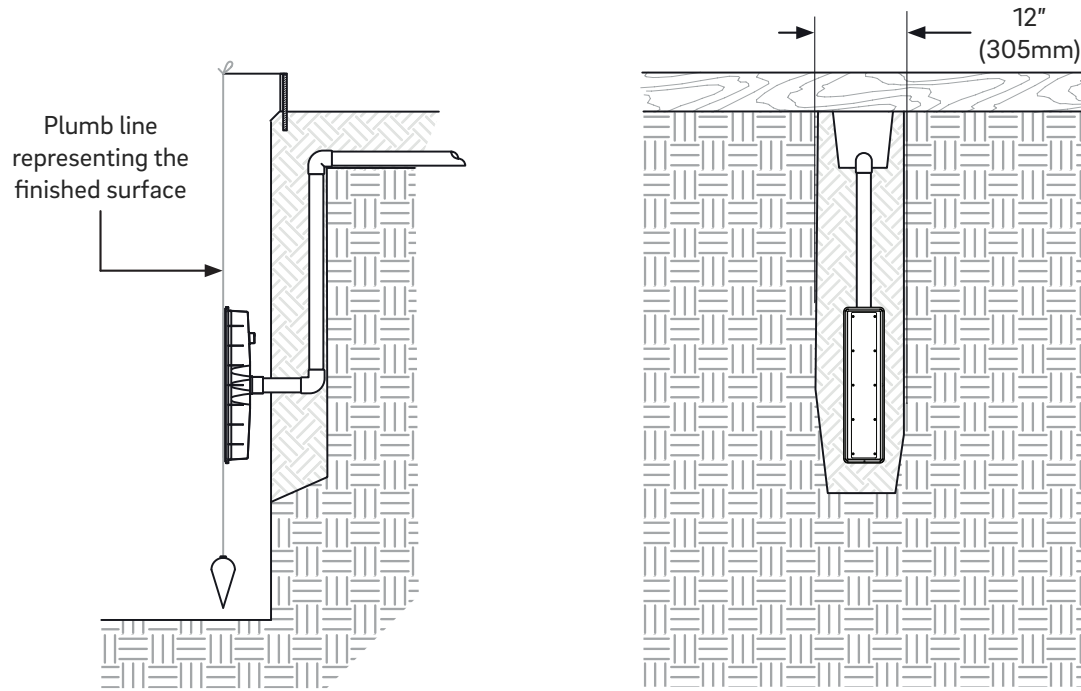

Figure 14

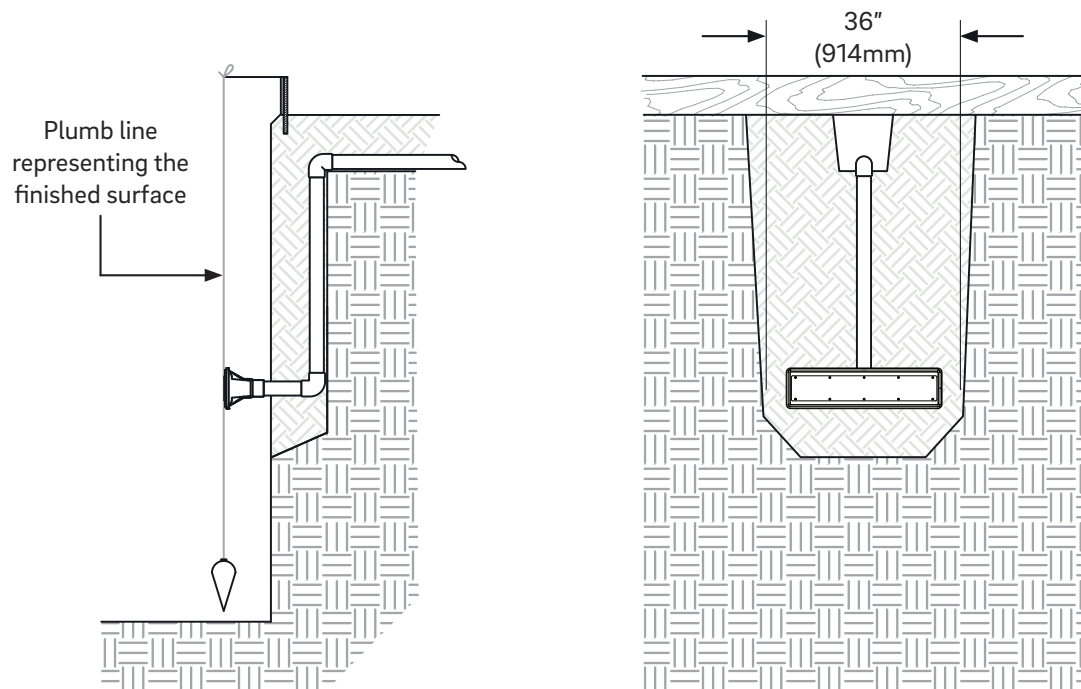

Figure 15

Split Drain

NOTE

Some local laws may necessitate the need for a split suction outlet regardless of the certified 'unblockable' classification of the AVSC drain. In such instances, it is recommended that the additional suction outlet have an equal or greater maximum flow rate than the AVSC drain. Be advised that the suction outlet that has the lowest maximum flow rate will dictate the total maximum flow rate on the main suction line.

Although the AVSC drain has been certified as unblockable, the following configuration should be followed when a split suction is desired.

The distance of pipe between points 'a to b' and 'c to d' must be of equal distance in order to maintain hydraulic balance when using the same pipe size between sections. Different pipe sizes may be utilized as long as hydraulic balance between ports can be maintained (Figure 16).

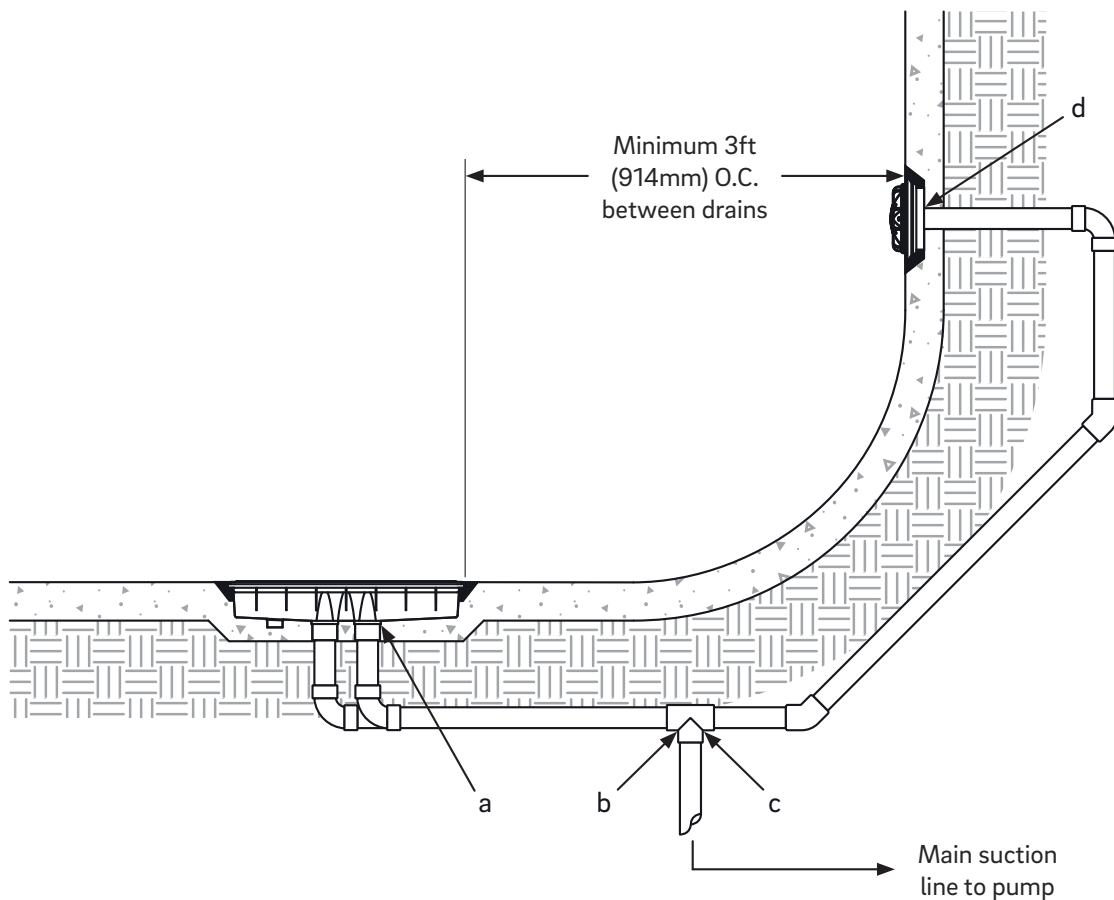

Figure 16

Steel and Concrete

1. The steel reinforcement bar must be bent so that the steel basket is below the AVSC drain, positioned half-way between the bottom of the sump and the bottom of the trench (Figure 17a & 17b).

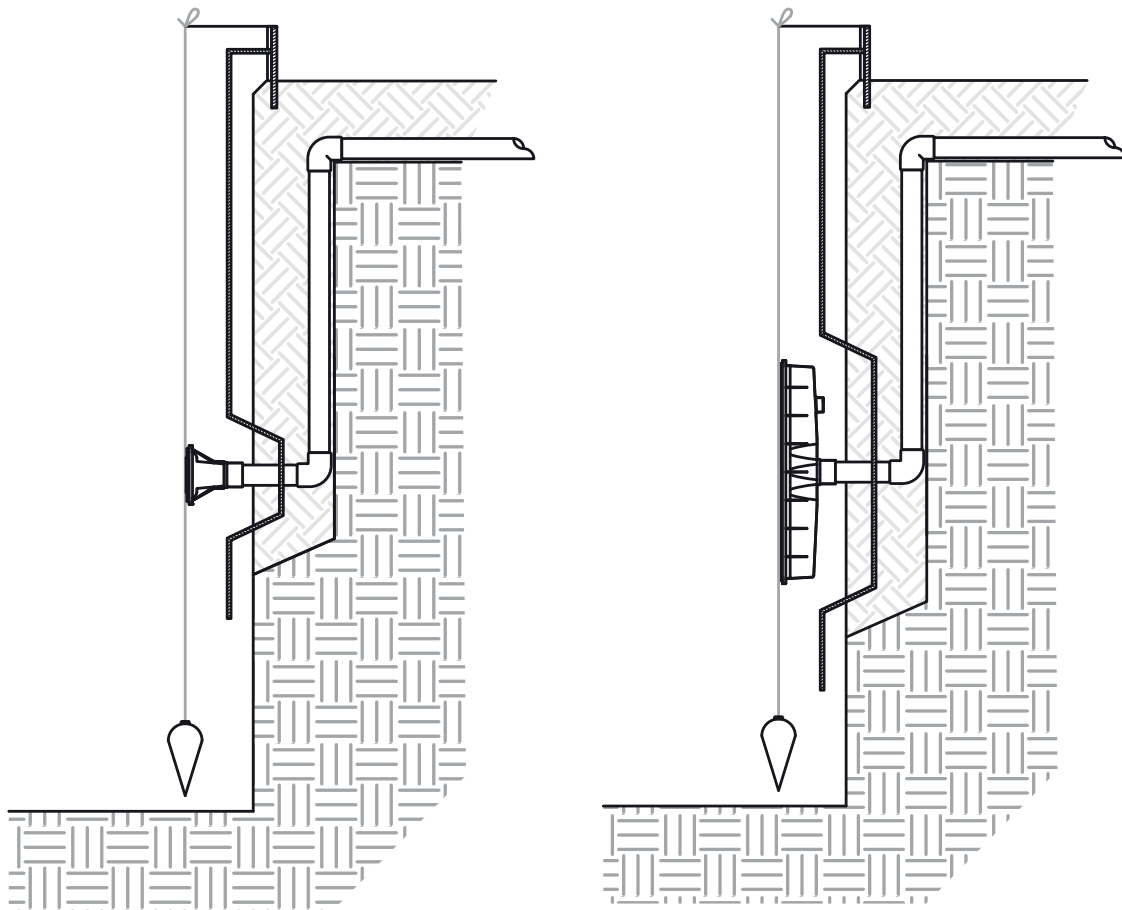
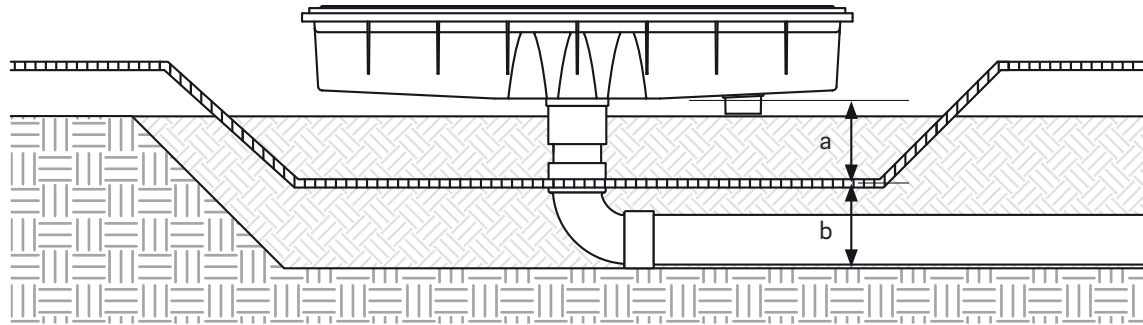

Figure 17

2. Make sure the plastic construction cover is secured in the AVSC drain to prevent concrete entering the drain sump (Figure 1a).
3. When applying shotcrete or gunite, begin by distributing the material around the base of the AVSC drain to help stabilize the unit. Allow this material to cure for a bit as other areas in the pool are shot. This will help to keep the drain locked in place and prevent movement as the hose moves around the bottom of the pool during the remainder of gunite or shotcrete process. After the other areas have been shot, return to the AVSC drain to finish shooting and forming the concrete around the drain.
4. Finish the wall around the drain by making a '2-finger swipe' under the waterstop leaving a void of approximately 1/2 inch below the waterstop. This will ensure enough room for the dry-pack material to be applied, creating the watertight seal.

Finished Surface

1. Before the finished surface is applied, make certain that the plastic construction cover is still securely sealed and in place to prevent the finish material from entering the sump of the AVSC drain.
2. To ensure a watertight seal, properly apply a drypack under and around the void surrounding the water stop. The finished surface should be flush with top of drain (Figure 18).
3. Before filling the pool with water, remove the plastic construction cover.
4. Remove the test plug from the AVSC drain's sump (Figure 1e) and glue in the safety shield with the supplied packet of glue (Figure 1d).
5. Install the cover onto the AVSC drain (Figure 1c) by using ONLY the supplied Torx safety screws (Figure 1b).

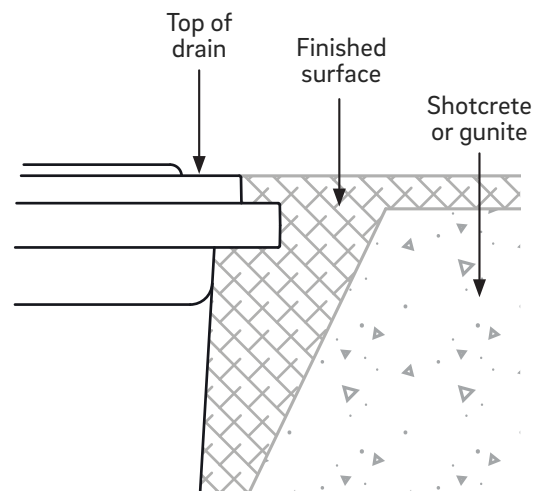

Figure 18



Equipment Plumbing

Standard Setup

When using a standard skimmer, the suction should be diverted so that the suction line from the main-drain is shut about half way and the suction line from the skimmer is completely open (Figure 19). This arrangement will result in the skimmer suction pulling as much debris from the surface of the water before sinking to the bottom of the pool.

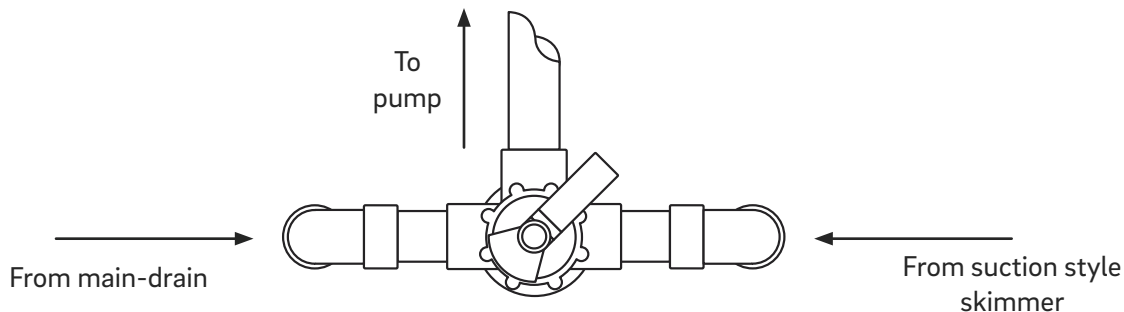

Figure 19

QuikSkim and QuikSkim-Ultra Venturi Setup

When the QuikSkim or QuikSkim-Ultra skimmer is installed on a pool that is set up to use the venturi skimming feature, the suction should be diverted so that all of the water is pulled through the main-drain and none of the suction is pulled from the skimmer (Figure 20). This arrangement will result in the main-drain providing maximum debris removal from the bottom of the pool, while the QuikSkim venturi skimmer provides maximum debris removal from the surface, without sacrificing suction by sharing with the main-drain.

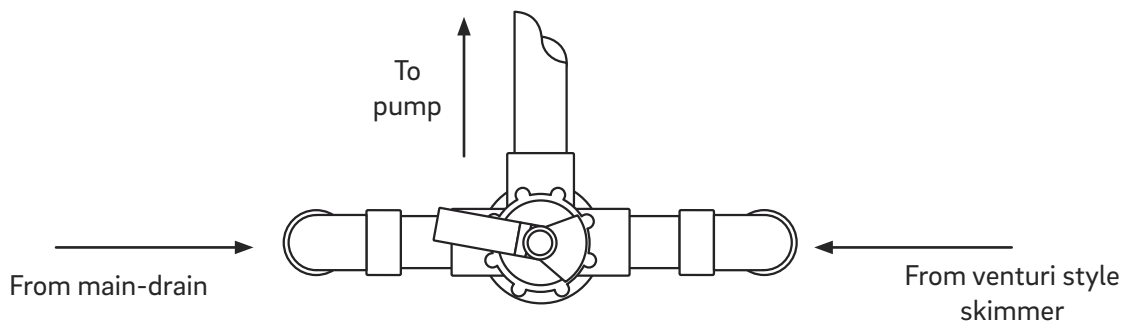

Figure 20

Winterization Setup

1. In order to evacuate the lines during the winterization process it is recommended that a 2-Way shut-off valve be installed on each suction branch-line preceding the main-line feeding the pump (Figure 21).

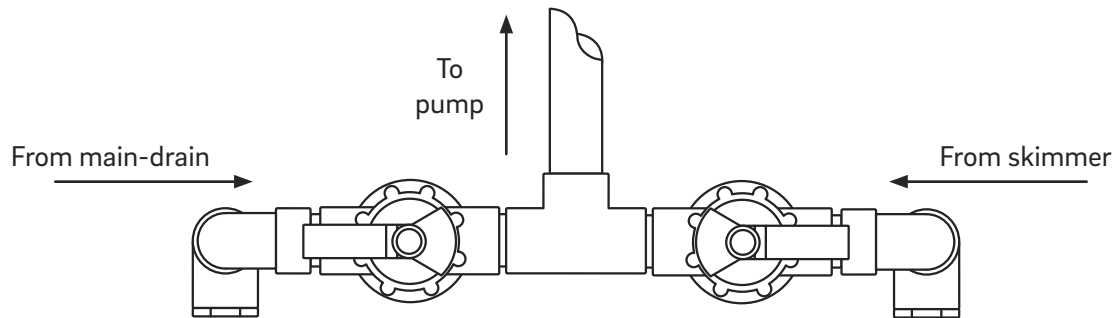

Figure 21

2. Between the 2-Way shut-off valve and the drain, install a Tee fitting with a 2 inch threaded branch. This will allow a 2 inch threaded plug to be removed later during the winterization process (Figure 22).

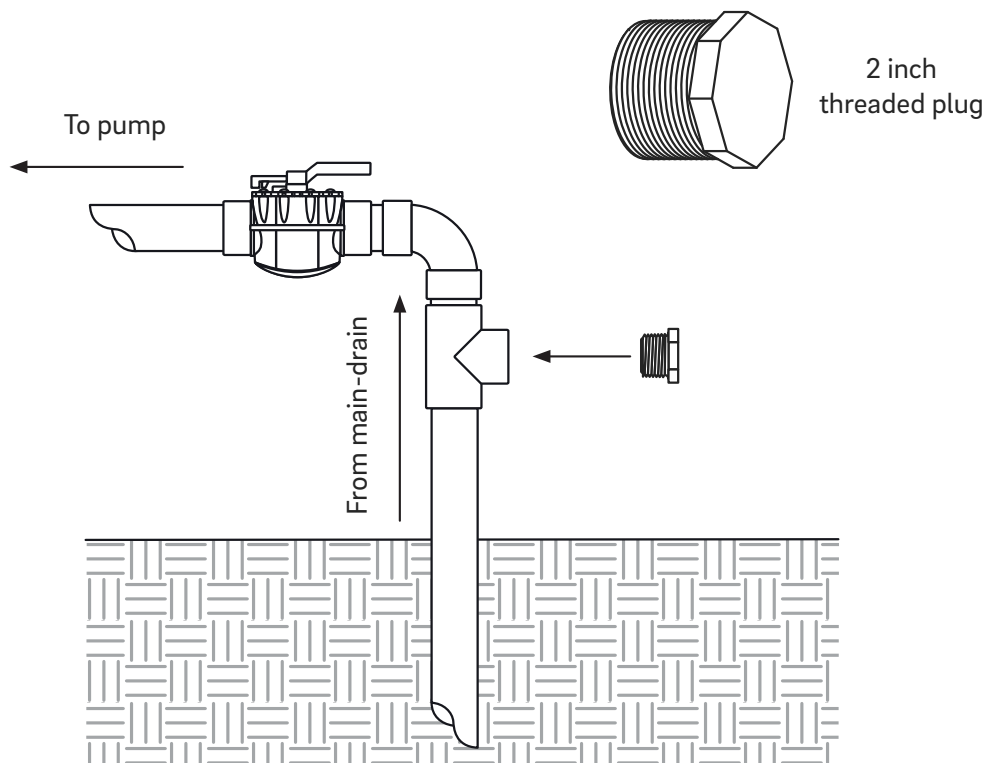

Figure 22

3. Ensure the suction line coming from main-drain is shut off.
4. Remove the 2 inch threaded plug (Figure 22) and replace it with a 2 inch thread by 1.5 inch slip reducer bushing (Figure 23).
5. Install and secure a plug containing an air valve into the 1.5 inch slip portion of the reducer bushing.
6. With the main-drain valve closed, blow out the main-drain line for a minimum of 30 seconds. This will provide an airlock in the line and prevent water from freezing in the pipe.

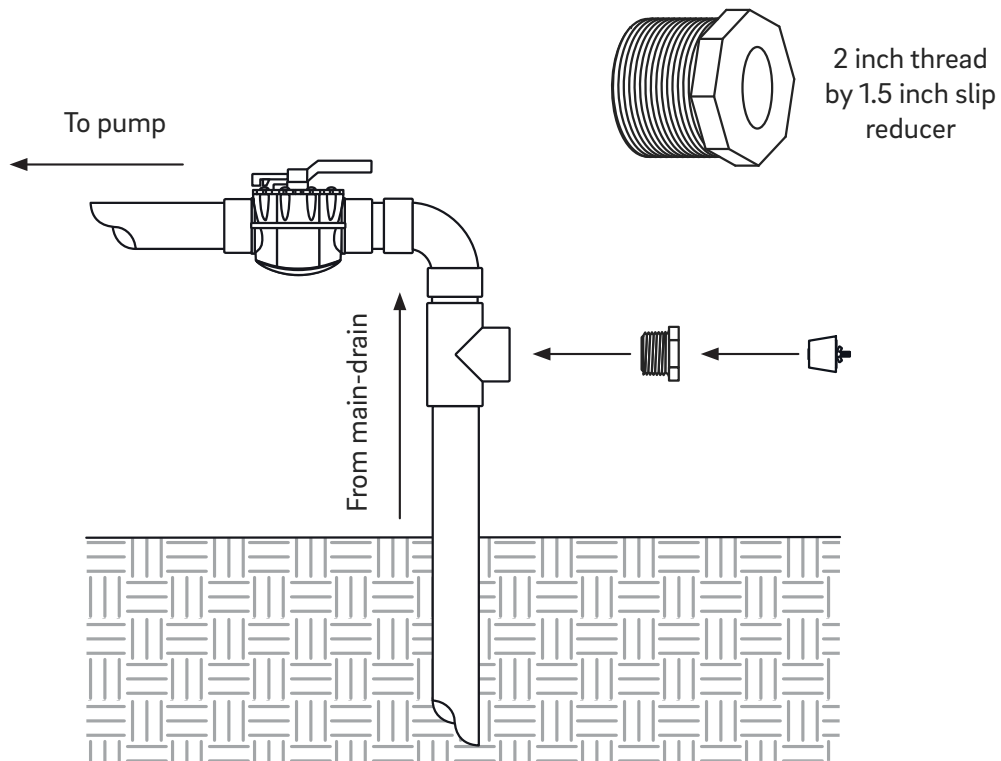

Figure 23



Limited Warranty

To original purchasers of this equipment, A&A Manufacturing will warrant the AVSC drain from defects in materials and workmanship for a period of one year from the date of purchase.

The limited warranty excludes damage from freezing, negligence, improper installation, improper use or care or any Acts of God. Parts that fail or become defective during the warranty period shall be repaired or replaced, at A&A Manufacturing's option, within 90 days of the receipt of defective product, barring unforeseen delays, without charge. Proof of purchase is required for warranty service. In the event proof of purchase is not available, the manufacturing date of the product will be the sole determination of the purchase date. To obtain warranty service, please contact the place of purchase. A&A Manufacturing shall not be responsible for cartage, removal, repair or installation labor or any other such costs incurred in obtaining warranty replacements or repair.

The A&A Manufacturing warranty does not apply to components manufactured by others. For such products, the warranty established by the respective manufacturer will apply. The express limited warranty above constitutes the entire warranty of A&A Manufacturing with respect to its pool products and is in lieu of all other warranties expressed or implied, including warranties of merchantability or fitness for a particular purpose. In no event shall A&A Manufacturing be responsible for any consequential, special or incidental damages of any nature.

Please retain for your records.

Date of Installation _____



A&A Manufacturing

AVSC Drain Warranty Registration Card

Directions: Please Fill out bottom portion completely and mail within 30 days of purchase or register your product online at www.aamfg.com

Please Mail to:
ATTN: WARRANTY DEPT,
A&A Manufacturing
3750 W Indian School Dr, Phoenix AZ 85019

PLEASE PRINT CLEARLY

Owner Information

First Name _____ Last Name _____

Street Address _____

City _____ State _____ Zip _____

Phone Number _____ Purchase Date _____

E-Mail Address _____

Product Model Number _____

Original Purchase Information

Company Name _____

Address _____

City _____ State _____ Zip _____

Phone Number _____

